

Gasmate®

CATERER 6 BURNER BBQ

Model No. GM312-001



IMPORTANT: RETAIN THESE INSTRUCTIONS FOR FUTURE USE.

For the most up-to-date version of this manual, please visit the product page on the Gasmate website as updates and improvements may be made periodically.

SafeLok®

LCC27 REGULATOR SUPPLIED WITH PROPANE MODELS

THIS LCC27 REGULATOR CAN ONLY BE USED WITH THE NEW SAFER INDUSTRY STANDARD LCC27 GAS CYLINDER CONNECTION.

Gasmate® is a registered trademark of Sitro Group Australia Pty Ltd www.gasmate.com.au
Aber Living, N.Z. www.gasmate.co.nz

GENERAL INFORMATION



IMPORTANT:

Read these instructions carefully prior to use. Familiarise yourself with the appliance before connecting it to its gas container. Keep these instructions for future reference.

GAS INSTALLATION CODES

- Barbecues must be used in accordance with the installation requirements of your gas supply authority, or the appropriate installation code detailed in the current revision of AS/NZS 5601.
- Barbecues for use with bottled gas are labelled 'Propane Gas.'
- Barbecues for use with natural gas are labelled 'natural gas' and must be installed by an authorised person. Check the gas type sticker attached to the barbecue.
- Do not install in, or connect to the consumer piping or gas supply system of a boat or caravan.

CLEARANCES

Minimum Clearances from combustible materials must be: Rear - 300mm Sides - 300mm Above - 800mm

SPECIFICATIONS

Barbecue specifications can be found on the data label attached to the door panel or the barbecue body.

HOSE & REGULATOR SAFETY

The regulator and hose assembly supplied with the barbecue are suitable for LPG only.

A gas regulator adjusted to have an outlet pressure of 2.75kPa is supplied for connection to the LPG cylinder.

The pressure regulator and hose assembly supplied with the barbecue must be used. Replacement pressure regulators and hose assemblies must be those specified by the barbecue manufacturer.

When connecting the hose and regulator assembly to the gas cylinder, take care to avoid unnecessary twisting or kinking of the flexible hose.

After the assembly has been secured, turn on the gas and check for leaks by brushing a soap and water solution over all connections.

If you are unable to correct the leak by tightening the connections, turn off the gas and contact the supplier immediately.

Always ensure the barbecue is kept away from flammable materials and the gas cylinder clear of any heat source.

When changing over from an empty gas cylinder to a full one make sure this procedure is carried out in a flame free atmosphere.

When changing over from an empty gas cylinder to a full one make sure this procedure is carried out in a well ventilated location, preferably outside, away from people and away from any sources of ignition; such as naked flames, pilot flames, electric heaters/equipment.

GAS CYLINDER USE & SAFETY

This is a low pressure barbecue and must only be used with the hose and regulator supplied. Your barbecue is designed for use with 9Kg LPG cylinders certified to AS2469.

The gas cylinder should be filled by a reputable gas supplier and visually inspected and requalified at each filling. Always check the cylinder collar for the test data status before use.

Always keep cylinder in an upright position. Always close the cylinder valve when the barbecue is not in use.

Do not subject gas cylinder to excessive heat.

NEVER STORE YOUR GAS CYLINDER INDOORS

If you store your barbecue indoors, ALWAYS disconnect the gas cylinder first and store the cylinder safely outside.

Cylinders must be stored outdoors in a well ventilated area out of reach of children, and must not be stored in a building, garage or any other enclosed area.



If you smell gas

1. Shut off gas to the barbecue at its source, if possible.
2. Extinguish any open flame.
3. Open hood.
4. If odour continues immediately call your gas supplier or fire department.

SPECIFICATIONS

MODEL	GAS TYPE	PRESSURE kPa	INJECTOR SIZE	GAS CONSUMPTION	MANIFOLD THREAD	A.G.A APPROVAL
GM312-001	Propane	2.75	1.05mm	84MJ/h	5/8"-18 UNF	AGA 8242 G

Detail on your specific model can be found on the data label attached to the BBQ body.

Manifold connection thread is 5/8"-18 UNF.



WARNING

The BBQ is designed for use with Propane gas and is for OUTDOOR use only.

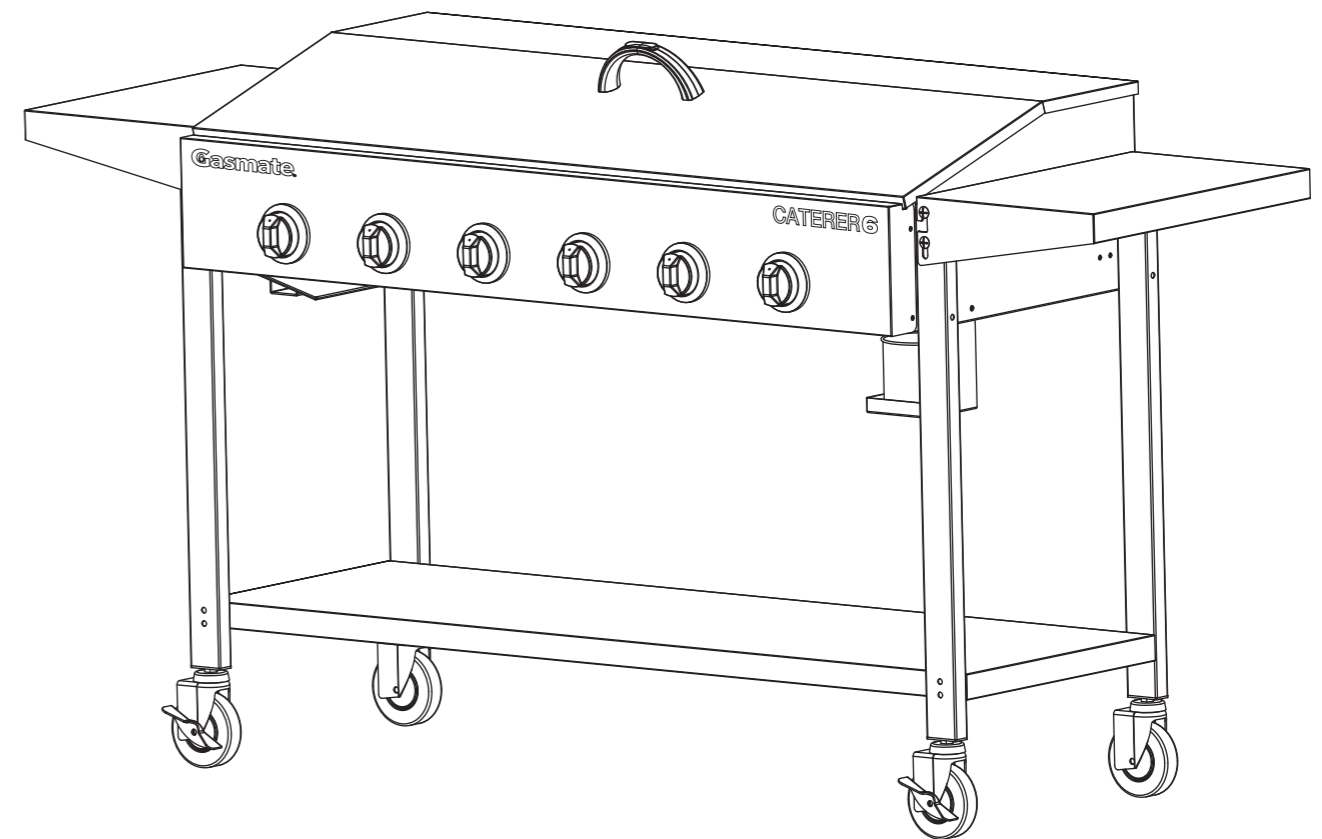

GENERAL INFORMATION



FOR YOUR SAFETY

Failure to comply with these instructions could result in a fire or explosion which could cause serious bodily injury, death or property damage.

CAUTION: Accessible parts may be very hot.

Keep young children away.

DO NOT spray aerosols in the vicinity of this appliance while in operation.

DO NOT use or store flammable materials in or near this appliance.

DO NOT place articles on or against this appliance.

DO NOT modify this appliance.

DO NOT move this barbecue during use.

Turn off gas supply at the gas cylinder after use.

Parts sealed by the manufacturer or their agent must not be manipulated by the user. This barbecue is only to be used and stored outdoors.

- Never operate this barbecue without a regulator.
- Do not test for gas leaks with an open flame.
- If this information is not followed exactly a fire causing death or serious injury may occur. Do not store a spare gas cylinder under or near this barbecue. This barbecue is only to be used and stored outdoors.
- If there is a leak on your appliance (smell of gas) immediately attempt to turn off the cylinder valve. Remove the appliance to a well ventilated location away from any ignition source. Only check for leaks outdoors using soapy water. DO NOT try to detect leaks using a flame.
- Check for leaks by spraying a soapy water solution over all connections. If you are unable to correct the leak by tightening the connections, turn off the gas and contact customer service immediately.
- Only use the hose assembly as supplied with this appliance for connection to the cylinder - DO NOT USE AN ADAPTER AT THE CYLINDER CONNECTION.
- After use, turn the appliance control knobs off, wait for the flame to go out then turn the gas cylinder valve off.
- Avoid twisting or kinking the flexible hose.
- Do not store or use petrol or other flammable liquids in the vicinity of this or any other appliance.
- Do not store empty or full spare gas cylinders under or near this or any other appliance.
- Never test for gas leaks with a lit match or open flame. Never light barbecue with hood closed or before checking to ensure the burner tubes are fully seated over gas valve orifices.
- Never lean over cooking surface when lighting.
- Never alter or modify the regulator or gas supply assembly.

- This barbecue must not be used indoors.
- Only use in well ventilated areas.
- CARBON MONOXIDE HAZARD - USING THIS APPLIANCE IN AN ENCLOSED SPACE MAY CAUSE DEATH. DO NOT USE IN CARAVANS, TENTS, MARINE CRAFT, CARS, MOBILE HOMES OR SIMILAR LOCATIONS.
- This appliance shall only be used in an above ground open-air situation with natural ventilation, without stagnant areas, where gas leakage and products of combustion are rapidly dispersed by wind and natural convection.
- Ensure the barbecue is set up on a level and stable surface.
- Do not move the barbecue while in use or when hot. Remove the drip tray before moving.
- DO NOT replace the grill with an extra hotplate. The warranty will be voided and it violates the gas approval, the grill provides the ventilation needed for the BBQ to operate safely. It is not designed to be a solid hotplate device.

IF THERE IS A LEAK

- Turn the cylinder off.
- Ventilate the area to disperse gas.
- Check all connections.
- If leak persists, keep the cylinder upright. Keep skin away from any gas or liquid escaping from the cylinder.
- Keep the cylinder at least 20 metres away from any sparks or ignition sources, including electrical equipment, camera flashes, engines and motors.
- Disperse gas by encouraging maximum ventilation and spraying with a fine water spray.

IF THERE IS A FIRE

- If the fire is at the barbecue, turn the gas off at the cylinder. Smother the flames with a wet cloth, fire blanket or extinguish using a fire extinguisher.
- If the fire is at the cylinder, or you can not get to the valve to turn the gas off, contact the fire brigade immediately.
- Using a garden hose, direct the water to the middle of the cylinder to keep it cool. Try not to extinguish the flame. At least if the gas is burning, it won't be able to build up pressure and explode.

LOCATION OF YOUR BARBECUE

DO NOT use your barbecue in garages, porches, breezeways, sheds or other enclosed areas. Your barbecue is to be used OUTDOORS. The barbecue is not intended to be installed in or on recreational vehicles and/or boats and should not be placed under any surface that will burn. Do not obstruct the flow of combustion and ventilation air around the barbecue housing.

PROTECT CHILDREN

Keep children away from barbecue during use and until barbecue has cooled after you have finished. Do not allow children to operate barbecue.

Always ensure that no sporting or physical activities are carried out in close proximity to the barbecue during use and while still hot.

GENERAL ASSEMBLY

Remove the barbecue and components from the packing carton. Check against parts list and lay components out within easy reach. Do not throw the carton away, unfold flat and use as a protective work surface. Contact your supplier for replacement parts if necessary.

TOOLS YOU WILL NEED

Standard Phillips-head screw driver (or cordless drill and bits), an Adjustable spanner and scissors.

CHECK BARBECUE FOR ANY DAMAGE

Inspect barbecue parts as you proceed. Contact your supplier for assistance regarding replacement of any damaged or missing parts. Do not assemble or operate a barbecue that appears damaged. Barbecues for use with gas cylinders are labelled 'PROPANE'. Check labelling at the gas connection on your barbecue.

ASSEMBLY INSTRUCTIONS

Before assembling the barbecue, read these Instructions carefully.

Assemble the barbecue on a flat, clean surface.

The barbecue is heavy.

NOTE: Do not fully tighten all the nuts during the initial stages of assembly.

Caution: Sheet metal can cause injury. Wear gloves when assembling the barbecue.



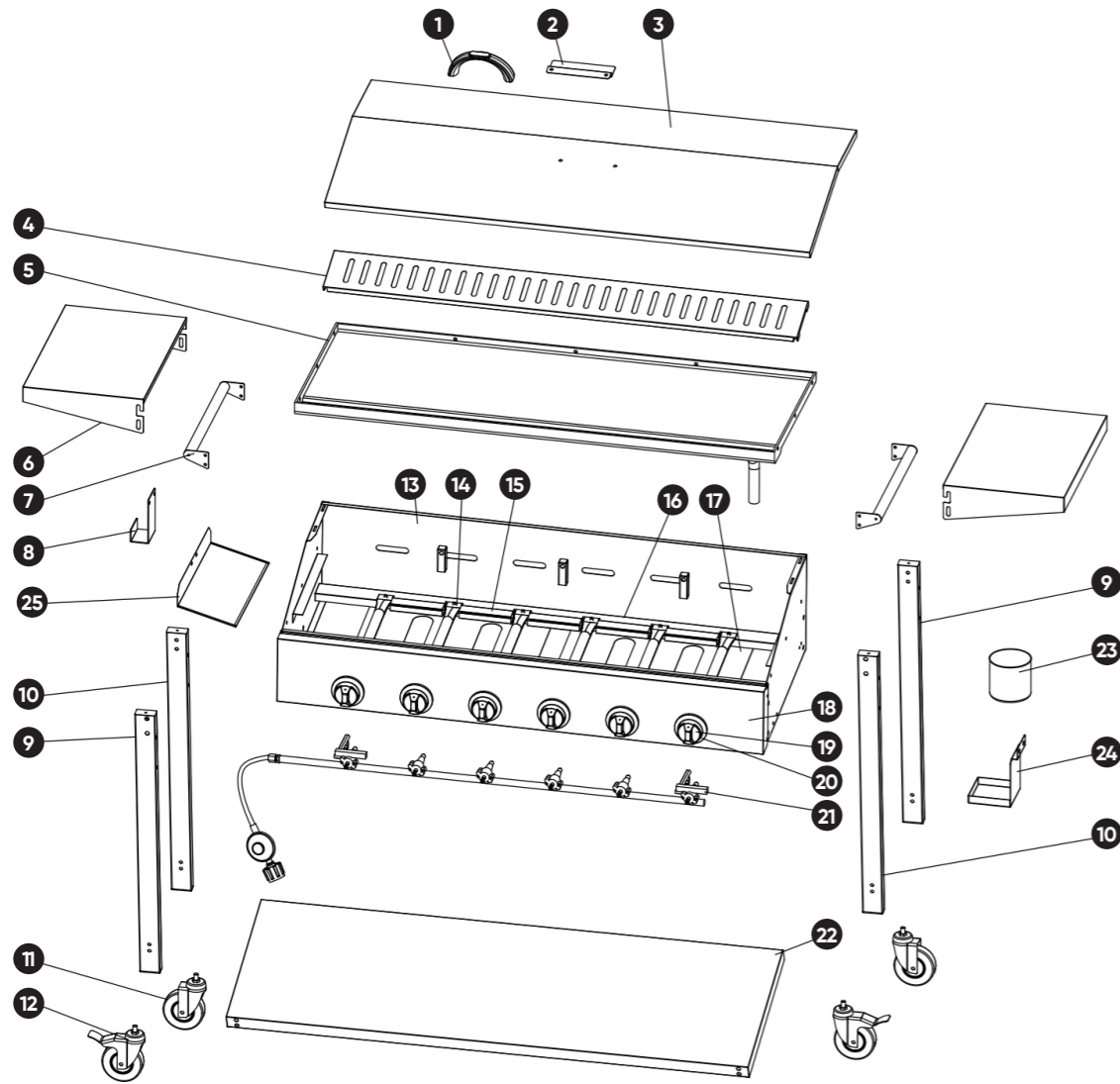

CATERER 6B EXPLODED DRAWING AND PARTS LIST



No.	Description	QTY
1	Lid Handle	1
2	Lid Hook	1
3	Lid	1
4	Warming Rack	1
5	Hotplate	1
6	Side Shelf	2
7	Side Handle	2
8	Cylinder Hook	1
9	Leg A	2
10	Leg B	2
11	Castor without Brake	2
12	Castor with Brake	2
13	Firebox	1

No.	Description	QTY
14	Burner	6
15	Cross Igniter	5
16	Burner Support	1
17	Heat Shield	2
18	Control Panel Assembly	1
19	Knob	6
20	Bezel	6
21	Manifold	1
22	Bottom Shelf Panel	1
23	Grease Cup	1
24	Grease Cup Holder	1
25	Cylinder Heat Shield	1

HARDWARE

A 	B 	C 	D 	E 
M6x65mm (x8)	M6x40mm (x8)	M6x12mm (x6)	M5x12mm (x8)	M6 Shoulder Screws (x8)

IMPORTANT: REMOVE ANY TRANSIT PROTECTION MATERIAL BEFORE USE.

TOOLS: Phillips Head Screwdriver, Adjustable Spanner

ASSEMBLY INSTRUCTIONS

STEP 1

Lay the firebox on its side. Attach the legs to the body using 8 x M6x65mm screws ensuring the side shelf nutserts (circled) are on the outer edge of the legs. Use 8 x M6x40mm long screws for the lower section of legs that attach to the bottom shelf panel. Screw the castors into the legs as shown.

A 	M6x65mm (x8)
B 	M6x40mm (x8)

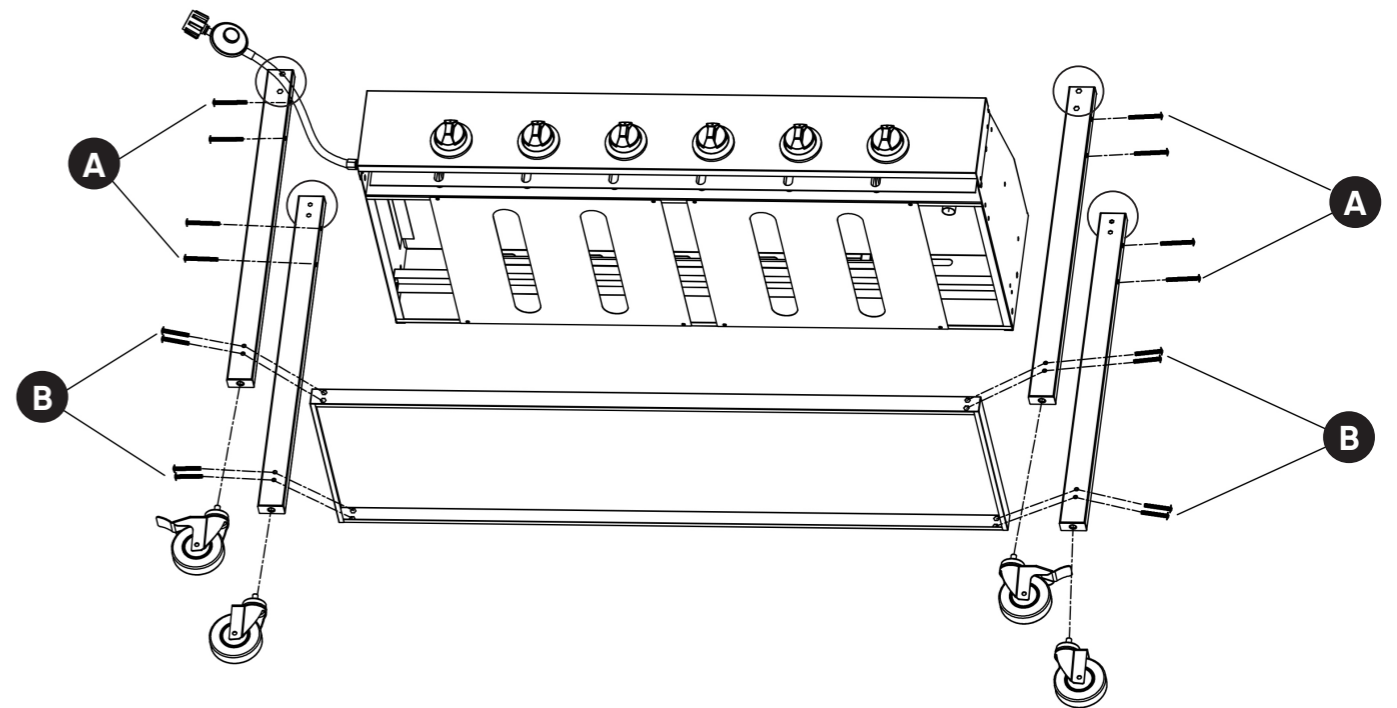

STEP 2

Attach the handles to the top of the legs using 8 x M5x12mm long screws, then attach the cylinder hanging hook, heat shield and grease cup holder as shown below using 4 x M6x12mm long screws.

C  M6x12mm (x6)

D  M5x12mm (x8)

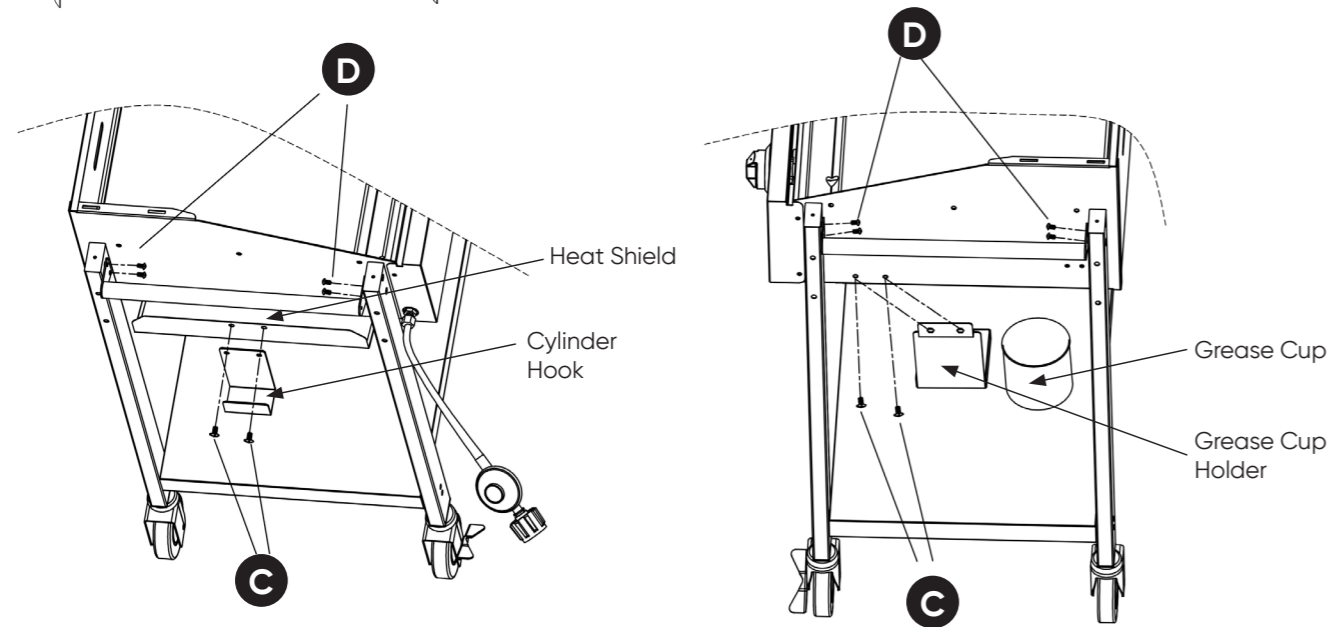

STEP 3

Attach the folding side shelves as shown using 8 x M6 shoulder screws.

E  M6x8mm (x8)

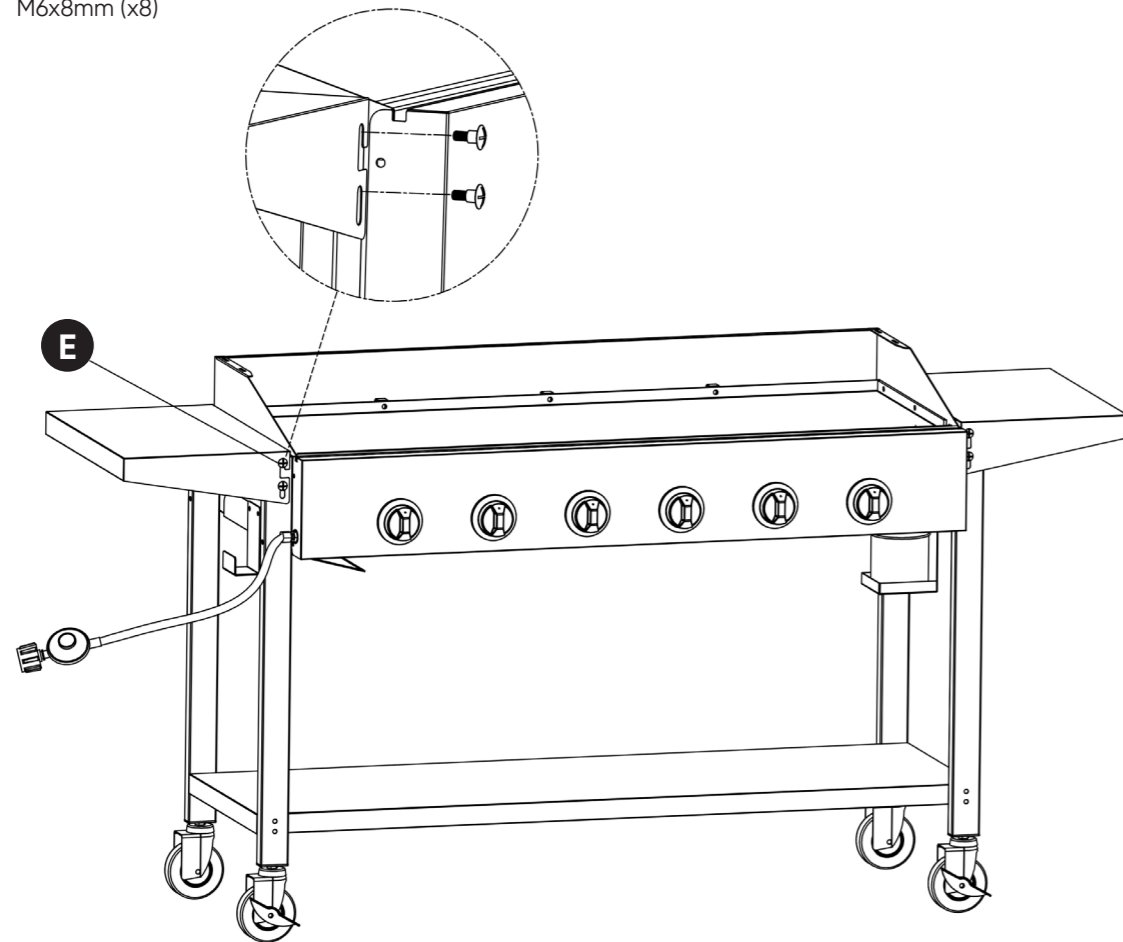

STEP 4

Attach the handle to the lid ensuring the lid hook is oriented as shown on the underside using 2 x M6x12mm screws. The lower wire rack and warming rack can be installed as required.

C  M6x12mm (x2)

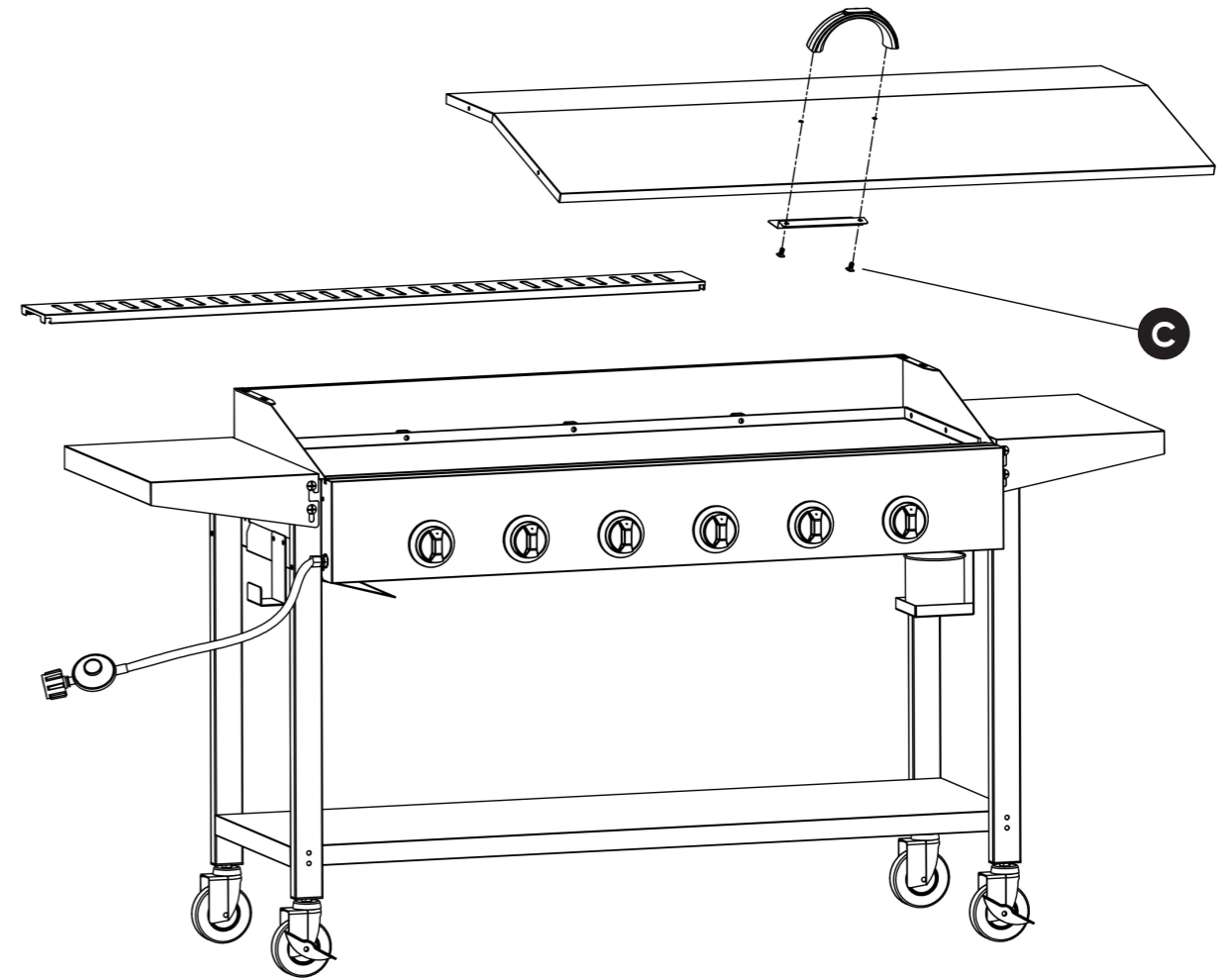

ASSEMBLY INSTRUCTIONS

STEP 5

Attach the regulator to your gas cylinder.

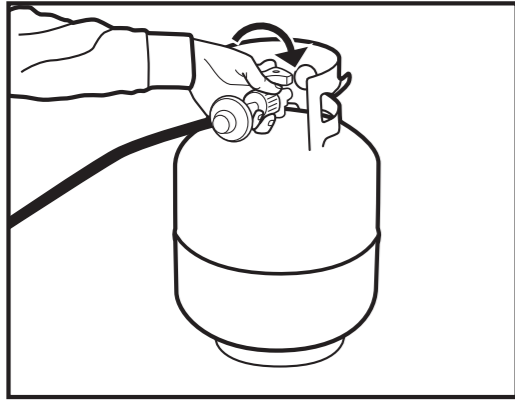

STEP 6

Turn on the gas cylinder ensuring that all of the controls on the BBQ are turned OFF at this point. DO NOT ATTEMPT TO LIGHT THE BBQ.

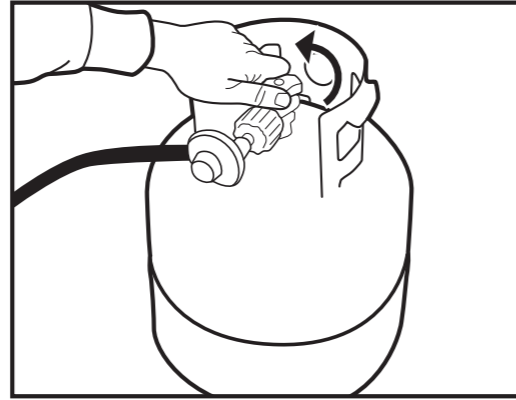

STEP 7

Use a solution of soapy water (dishwashing liquid and water is fine). Brush it on or use a spray bottle as shown in the drawing. Ensure the connections have a good coating.

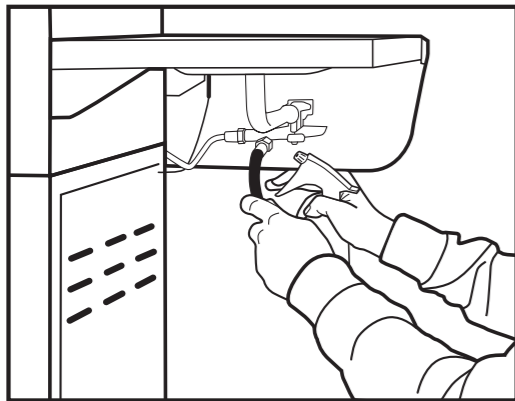

STEP 8

If the connection is leaking, bubbles will start to grow in the soapy solution. If this happens shut off the gas supply at the cylinder.

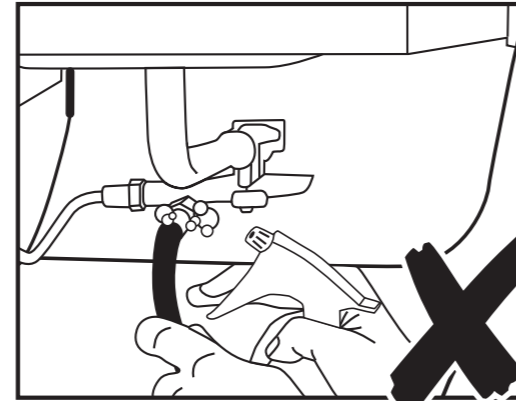

STEP 9

Tighten the connections using a crescent then repeat steps 7-8.

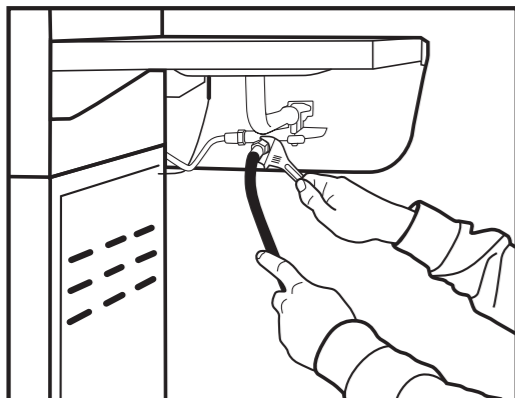

STEP 10

The connection is gas tight when no bubbles grow around the gas connection.

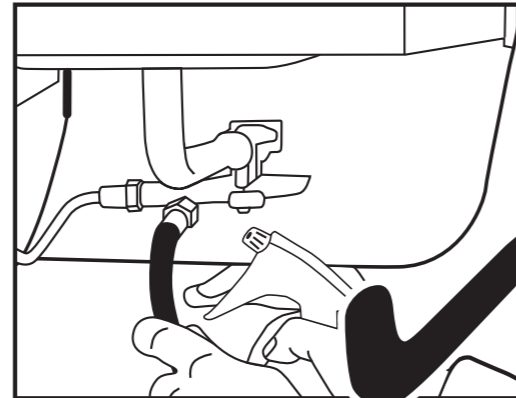

GENERAL ASSEMBLY

CONNECTING & DISCONNECTING TO GAS SOURCE



IMPORTANT:

- Before connecting and disconnecting barbecue to gas source, make sure burner controls are in 'OFF' position.
- **CAUTION:** When the barbecue is not in use, the gas must be turned off at the cylinder.
- Check that the seals between the appliance and the gas cylinder are in place and in good condition before connecting the gas cylinder.
- Do not use this appliance if it has damaged or worn seals.
- Check performance of burner prior to using.

Familiarise yourself with the general information and safety guidelines located at the front of this manual.

CHECK:

1. The cylinder is filled. A sloshing sound will be heard when shaken.
2. The burner controls are in the 'OFF' position.

CONNECTING

1. Ensure cylinder valve is in its full off position.
2. Check for any damage to either the cylinder connection or the hose. NEVER attempt to use damaged equipment.
3. When connecting the hose to the cylinder tighten the nut to a positive stop by hand.
4. Open cylinder valve fully. If a leak can be heard at either end of the hose turn cylinder off and tighten joint. Wait 5 minutes before re-testing and use a soapy water solution to check the joint. If bubbles appear the connection will need to be re-tightened.

Refer to previous page for more detailed instructions on connecting the appliance to the cylinder.

DISCONNECTING

1. Ensure the burner control is in the 'OFF' position.
2. Ensure cylinder valve is in the full off position.

For storage and cylinder exchange, disconnect hose at the cylinder only, DO NOT disconnect hose from appliance.

REGULATOR SAFETY FEATURE

The SafeLok LCC27 regulators fitted to this BBQ (the part that attaches to the gas cylinder to regulate the flow of gas) have a safety feature included that restricts gas flow in the event of a gas leak. You can inadvertently activate this safety feature without having a gas leak. This typically occurs when you turn on the gas using the barbecue control knob before you turn on the gas cylinder valve. If the gas regulator safety feature activates, the barbecue will operate with reduced output as gas flow is restricted.

These steps should be taken first to reset the gas regulator safety device:

1. Ensure the barbecue lid is off.
2. Turn gas cylinder valve off.
3. Turn off all control knobs.
4. Disconnect the regulator from the gas cylinder.
5. Wait 30 seconds.
6. Reconnect the regulator to the gas cylinder.
7. Leak test the connection using a soapy water solution. Ensure no bubbles appear before proceeding.
8. Slowly open the gas cylinder valve all the way. Do not put excessive force on the valve at the full open position, to avoid damaging the valve.
9. Light barbecue as per the instructions provided.

LIGHTING PROCEDURE

Before lighting your barbecue for the first time, read the instructions fully to ensure the barbecue is assembled correctly and is ready for use.

BURNER OPERATION & IGNITION SYSTEM CHECK

1. Remove the lid of the barbecue before attempting to light the burners.
2. Turn all the control knobs clockwise to "OFF" position.
3. With cylinder valve in "OFF" position turn the control knob on the far left or far right anti-clockwise to "HIGH" (a single click is heard). Check for sparking to the burner.
4. If spark is not evident at the burner ignition point, check that the ignition lead is firmly attached to the control and sparker tip.
5. With sparking established turn the cylinder valve 'ON'.
6. Push down and turn the control knob on the far left or far right anti-clockwise to "HIGH" again. This will light the burner. Observe if the burner has lit. If not, repeat this process.

7. If the burner fails to ignite after several attempts turn off gas supply at cylinder valve and the control knob off (clockwise). Wait five minutes before attempting to relight with ignition sequence.
8. Following successful ignition, light the remaining burners in sequence, turn control knobs anti-clockwise to 'HIGH' starting with the burner closest to the ignition burner. Subsequent burners will cross-light from the lit one next to it.
9. Adjust the heat by turning each control knob to the "HIGH"/"LOW" position.
10. To turn the barbecue 'OFF' turn the cylinder valve to the 'OFF' position, then turn the control knobs on the barbecue clockwise to the 'OFF' position.

If re-ignition is necessary while the gas barbecue is still hot, you must wait for a minimum of 5 minutes before commencing to re-ignite (this allows accumulated gas fumes to clear).



IMPORTANT:

- **NOTE:** If for some reason, ignitor fails to produce a spark at the electrode, BBQ can be lit by a long BBQ match. With the lid off, insert a lit match underneath body into the closest opening to a burner tube. Push and turn the respective control knob to HIGH. Burner ignition can be checked through the opening used for lighting. Subsequent burners will cross light.
- Do not smoke when attempting to ignite BBQ.
- Never use volcanic rock, heat beads or other material.
- Always use protective gloves when handling hot components.

BURNER OPERATION & IGNITION SYSTEM CHECK

Problem	Possible Reason	Solution
Burner will not ignite	Valve on cylinder is closed	Open the valve on the cylinder
	Control knob is closed	Push in and turn the knob anti-clockwise
	Electronic igniter is faulty	Use a long barbecue match (see info on this page)
Food is not cooking or is taking too long	Burner has gone out	Check that the gas bottle is not empty and re-ignite the burner
	Cooking surface was not given enough time to warm up before the food was applied	Remove the food and give the burner time to warm the cooking surface (5-10 minutes)
	There is too much food on the cooking surface	Cook smaller portions
Flames on the burners burn in yellow or orange flames combined with the smell of gas	The inlets are obstructed	Check for spiders and insects or other obstructions. Clean the burner assembly (see page 14)
	Air shutter on the burner is not adjusted correctly	Adjust the air shutter correctly (see page 16)
	There is a gas leak	Perform a leak test (see page 10)
Flame is low while control knob is on high temperature setting or burner does not ignite	Check if the gas cylinder is empty	Install a full gas cylinder and check for leaks
	Check if the gas hose is bent or kinked	Straighten the gas hose
	The Excess Flow device has been activated. If the LPG cylinder valve is opened to allow gas flow while a burner control valve is already open, the surge of pressure will cause the device to activate	Make sure all burners are set to 'Off' before opening LPG cylinder. Wait 5 seconds after opening LPG valve. Light burners one at a time
When using the igniter function, the burner does not ignite	Check if gas flows out by following the manual lighting instructions	If the burner lights up, check if the igniter is working properly. If the burner does not light up, clean the burner assembly (see page 14)
	Check if the electrodes and ignitor cables are properly connected to the tube burners.	Install the electrodes properly to the tube burners and check if all ignitor cables are installed correctly
	Check if the electrodes are covered by cooking residue	Clean the burners as described in cleaning and care. Additionally clean the electrode tip with alcohol

BURNER OPERATION & IGNITION SYSTEM CHECK

Problem	Possible Reason	Solution
Flame pattern on the burners is inhomogeneous or does not run the whole length of the tube burner	Check if the burners are clean	Clean the burners as described in cleaning and care
Burner blows out	Burner isn't installed properly	Check all parts are aligned correctly
	Fuel mixture	Close the gap on the adjustable air shutter
	Gas supply is insufficient	Straighten the gas hose and check that the gas bottle is not empty

NOTE: If the appliance cannot be adjusted to perform correctly it should not be used until serviced or repaired.

OPERATING PROCEDURE

PREPARING COOKING SURFACE FOR FIRST USE

HOTPLATE SEASONING INSTRUCTIONS

What oil is best to use?

- Any plant based cooking oil
 - Pre rendered animal fat (no additives)
1. Wipe any debris off the hotplate.
 2. Turn the burners on HIGH for about 10 minutes
 3. Use tongs to grip a folded paper towel or cotton cloth, then spread 2 to 3 tablespoons of seasoning oil across the entire hotplate.

For best results, apply a light, even coating of the oil. This will ensure that the oil burns off cleanly and easily.

PREVENTING RUST

Use your BBQ regularly. Each use helps build up the seasoning layer, reducing the risk of rust.

We recommend after every use, add a layer of seasoning oil over the hotplate and edges.

PLEASE NOTE: In coastal or humid environments, more frequent re-seasoning may be required between uses.

PREHEATING

It is necessary to preheat the barbecue for at least 5 minutes before cooking certain foods, depending on the type of food and the cooking temperature. Food that requires a low cooking temperature, needs only a period of 2-3 minutes preheating.

COOKING TEMPERATURES

'HIGH' setting - Use this setting only for fast warm up, for searing steaks and chops, and for burning food residue from the grill plates after cooking is over. Rarely, if ever, do you use the 'HIGH' setting for extended cooking.

'MEDIUM' setting (mid-way between 'HIGH' and 'LOW'). Use this setting for most grilling, and for cooking hamburgers, sausages and vegetables.

'LOW' setting - Use this setting when cooking very lean cuts such as fish.

These temperatures vary with outside temperature and the amount of wind.

CARE & MAINTENANCE

It is recommended that the BBQ is regularly cleaned and should be serviced at least annually. Servicing must only be carried out by a licensed gas fitter or authorised person.

The hose and regulator should be checked for leaks and damage before each use and we recommend to replace the hose and regulator every 5 years.

Cleaning and general maintenance instructions are given below.

CLEANING THE COOKING SURFACE

We recommend it is best to clean the hotplate after cooking while it is still hot. Once you have finished cooking, turn off all burners and follow these steps:

1. Use a BBQ brush or spatula to push loose food debris into the fat cup.
 2. Wipe the hotplate with a paper towel.
 3. Pour a small amount of water onto the hotplate, then scrape the water and debris into the fat cup.
- For stubborn residue, use coarse salt to help lift stuck-on food.
4. Wipe the surface again with a paper towel and then dry thoroughly with a clean sheet of paper towel.
 5. Finish by applying a light coat of cooking oil to maintain seasoning and protect the hotplate.

CARE OF COOKING SURFACE

Use and care of the cooking surface is important. Do not use pans on the cooking surface. Do not overheat the cooking surface with the lid on or no food on the cooking surface.

FLASH-BACK

If fire occurs in and around the burner, immediately turn off gas at its source and turn the burner control to OFF, wait until the barbecue has cooled, then clean the burner tubes and burner ports as described in lighting and operating procedure.

Spiders and small insects occasionally spin webs or make nests in the burner tubes during warehousing and transit. These webs can lead to a gas flow obstruction which could result in a fire in and around the burner tubes. Cleaning with a soft brush before use and at least every six months is recommended.

This type of fire is known as 'FLASH-BACK' and can cause serious damage to your barbecue and create an unsafe operating condition for the user. Although an obstructed burner tube is not the only cause of 'FLASH-BACK' it is the most common cause and frequent inspection and cleaning of the burner tubes is necessary.

CLEANING THE FAT CUP

To avoid fat or grease dripping from the barbecue remove and empty the fat cup after each use. Wait until the fat cup is cool to touch before disposing of contents.

The fat cup should be washed periodically in a mild detergent and hot water solution.

CLEANING THE BURNER ASSEMBLY

1. Make sure the barbecue is cool.
2. Remove the burner by taking off the R-clip from the rear end of the burner.
3. Lift the burner up and away from gas valve orifice.
4. Clean the inlet of burner with small bottle brush or compressed air.
5. Remove all food residue and dirt on the outside of the burner surface.
6. Clean any clogged ports with a piece of stiff wire (such as an opened paper clip).
7. Inspect the burner for any damage (cracks or holes), If damage is found, replace with a new burner. Reinstall the burner, check to ensure that gas valve orifices are correctly positioned inside burner inlet.
8. Overlap 15mm between tube and nozzle when assembled.
9. Keep the centre line of tube and nozzle on one line.

WARNING: If the instructions above are not followed, an explosion may result, possibly causing serious bodily injury or death

STORING THE APPLIANCE

If the appliance needs to be stored for a prolonged period of time (e.g. over winter):

1. Set control knobs to off (pointing upwards).
2. Close valve at the gas cylinder.
3. Remove the gas cylinder from the appliance, by unscrewing the gas hose.
4. Carefully clean the appliance.
5. The appliance can be stored in a dry location indoors (e.g. garage)
6. The gas cylinder needs to be stored outdoors in a dry and well-ventilated location and out of reach of children!
7. Cover the appliance.

When removing the appliance from storage check for burner obstructions.



IMPORTANT:

- Beware of spiders and wasps. Burner tube should be inspected and cleaned periodically.
- This appliance must only be serviced by an authorized person.
- To avoid any flare-ups, it is recommended that the drip tray be checked and emptied regularly. Contents of the drip tray may be very hot during cooking. If emptied during extended cooking extreme caution should be taken and direct contact by hand should be avoided at all times. Allow to cool completely before disposing of the contents.

DIAGRAMMATIC REPRESENTATIONS OF OUTDOOR AREAS

The following figures are diagrammatic representations of outdoor areas. Rectangular areas have been used in these figures – the same principles apply to any other shaped area.

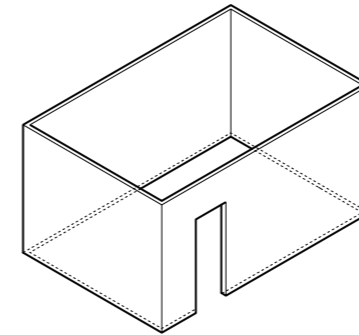

Outdoor Area - Example 1

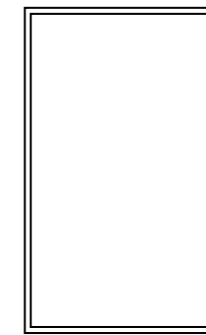

Outdoor Area - Example 2

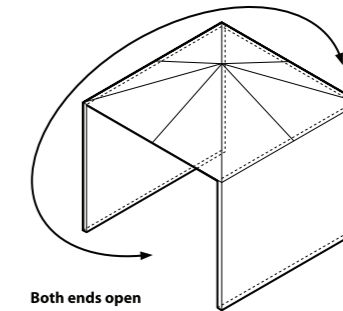

Both ends open

Outdoor Area - Example 3

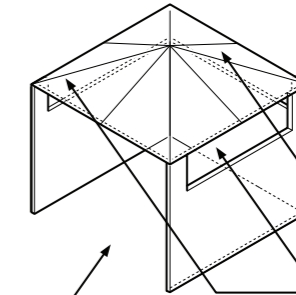
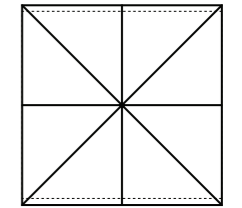

Open Side at least 25% of total wall area
30% or more in total of the remaining wall area is open and unrestricted

Outdoor Area - Example 4

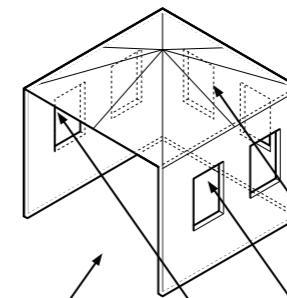

Open Side at least 25% of total wall area
30% or more in total of the remaining wall area is open and unrestricted

Outdoor Area - Example 5

This appliance shall only be used in an above ground open-air situation with natural ventilation, without stagnant areas, where gas leakage and products of combustion are rapidly dispersed by wind and natural convection.

Any enclosure in which the appliance is used shall comply with one of the following:

- An enclosure with walls on all sides, but at least one permanent opening at ground level and no overhead cover.
- Within a partial enclosure that includes an overhead cover and no more than two (2) walls.

- Within a partial enclosure that includes an overhead cover and more than two (2) walls, the following should also apply -

- (i) at least 25% of the total wall area completely open; and
 - (ii) at least 30% of the remaining wall area is open and unrestricted.
- In the case of balconies, at least 20% of the total of the side, back and front wall areas shall be and remain open and unrestricted.

FOR ANY QUERIES OR ASSISTANCE CALL

AUSTRALIA



Customer Service
(Australia only)

1300 174 876

Hours of operation:
Monday to Friday 8am - 5pm EST
Email: sales@sitro.com.au

For warranty keep your purchase receipt,
this will be required to make any claims under
the 1 year warranty.

NEW ZEALAND



Customer Service
(New Zealand only)

0800 161 161

Hours of operation:
Monday to Friday 8am - 5pm EST
Email: sales@aber.co.nz

For warranty details visit gasmate.co.nz.
Keep your purchase receipt, this will be required to
make any claims under the 1 year warranty.

Gasmate