



# GAS SMOKER

Model No. BQ2050W, BQ2053W

- Traditional style smoker for delicious smoking and slow cooking of foods
- Glass viewing window
- 10.5MJ/h burner
- Durable steel construction
- 3 Adjustable chrome plated wire racks
- 6 Hanging meat hooks
- Vitreous enamel smoker box
- 3 Heavy duty door and drawer handles
- Door mounted thermometer with chrome bezel
- 2 Side handles that double as tool hooks
- Includes water bowl and smoker box to add moisture and flavour when cooking
- Hose and regulator included
- For outdoor use only
- Universal LPG
- Gas certified to Australian Standards



## FOR YOUR SAFETY

If you smell gas:

1. Shut off the gas to the appliance.
2. Extinguish any open flame.
3. If odour continues, immediately call your gas supplier.

Do not store or use gasoline or other flammable vapour and liquids in the vicinity of this or any other appliance.

## FOR OUTDOOR USE ONLY

### WARNING:

Improper installation, adjustment, alteration, service or maintenance can cause injury or property damage.

Read the instructions thoroughly before installing or servicing this equipment.

Gasmate® is a registered trademark of:

Sitro Group Australia Pty Ltd [www.gasmate.com.au](http://www.gasmate.com.au)  
Aber Ltd - Hamilton, N.Z. [www.gasmate.co.nz](http://www.gasmate.co.nz)

---

**Important: Retain these instructions for future use.**

---

# READ ME FIRST

## LEAK TESTING

Please check for gas leakage the first time you are connecting the Smoker to the gas cylinder, and also each time you are replacing the gas cylinder or disconnecting/reconnecting any fittings. Inspect the hose before each use.

To check for gas leakage, turn on the gas supply at the gas cylinder, but do not switch on the burners inside the Smoker. The gas hose will now be filled with gas. Then pour water with soap over all connections. Any gas leakage should result in bubbles within 20 seconds. If a gas leakage is detected, tighten the connection. If the gas leakage persists, contact your supplier or place of purchase. As an alternative, you may use a gas leak detector, following the manufacturer's instructions, available at all major BBQ retailers. This provides an easier way to check for gas leaks.

**DO NOT USE NAKED FLAME FOR LOCATING GAS LEAKS. IF A LEAK PERSISTS, CALL AN AUTHORISED PERSON.**

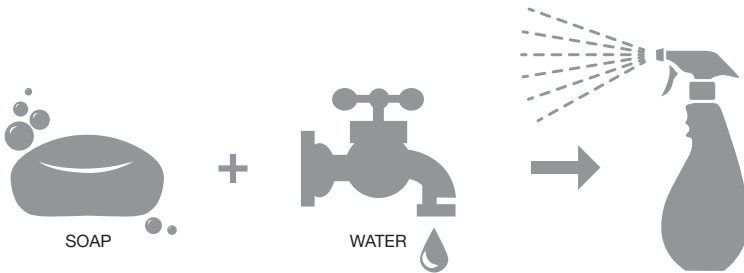

1. Add soap and water to spray bottle or soapy water with brush.



2. Turn off gas valves.

3. Turn gas cylinder on.

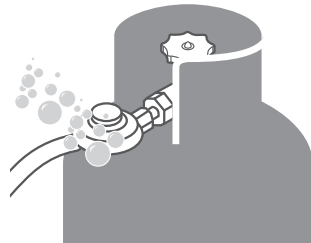
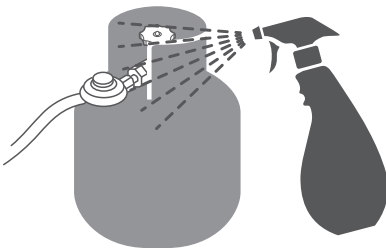

4. Spray or apply soapy water on gas connections.

5. If leak is present, bubbles will appear.

## GENERAL INFORMATION

### Gas Installation Codes

- Appliances must be used in accordance with the installation requirements of your gas supply authority, or the Australian Standard AS 5601.
- Appliances for use with bottled gas are labelled 'propane gas' or Universal L.P.G.
- Appliances for use with natural gas are labelled 'natural gas' and must be installed by an authorised person. Check the gas type sticker attached to the appliance.

### Clearances

Minimum Clearances from combustible materials must be:

Rear - 100mm Sides - 100mm Top - 1000mm

### Hose & Regulator Safety

The regulator and hose assembly supplied with the appliance are suitable for propane gas only. A gas regulator adjusted to have an outlet pressure of 2.75kPA is supplied for connection to the propane gas cylinder. The pressure regulator and hose assembly supplied with the appliance must be used. Replacement pressure regulators and hose assemblies must be those specified by the appliance manufacturer.

When connecting the hose and regulator assembly to the gas cylinder, take care to avoid unnecessary twisting or kinking of the flexible hose.

After the assembly has been secured, turn on the gas and check for leaks by brushing a soap and water solution over all connections.

If you are unable to correct the leak by tightening the connections, turn off the gas and contact the supplier immediately.

Always ensure the appliance is kept away from flammable materials and the gas cylinder clear of any heat source. When changing over from an empty gas cylinder to a full one make sure this procedure is carried out in a flame free atmosphere.

### Specifications

Appliance specifications can be found on the data label attached to the door panel or the appliance body. Hose connection thread at gas inlet is 5/8" - 18, U.N.F.

### Gas Cylinder Use & Safety

This is a low pressure appliance and must only be used with the hose and regulator supplied. Your appliance is designed for use with 9Kg propane gas cylinders certified to AS 2469.

The cylinder should be filled by a reputable gas supplier and visually inspected and re-qualified at each filling.

Always keep cylinder in an upright position. Always close the cylinder valve when the appliance is not in use.

Do not subject the cylinder to excessive heat.

### Never Store your Gas Cylinder Indoors.

If you store your appliance indoors, ALWAYS disconnect the cylinder first and store it safely outside. Cylinders must be stored outdoors in a well ventilated area out of reach of children, and must not be stored in a building, garage or any other enclosed area.

### Location of your Appliance

DO NOT use your appliance in garages, porches, sheds, breezeways, or other enclosed areas. Your appliance is to be used OUTDOORS. The appliance is not intended to be installed in or on recreational vehicles and/or boats and should not be placed under any surface that will burn. Do not obstruct the flow of combustion and ventilation air around the appliance housing.

### Check Appliance for any Damage

Contact your supplier for assistance regarding replacement of any damaged or missing parts. Do not operate a appliance that appears damaged.

### Protect Children

Keep children away from appliance during use and until appliance has cooled after you have finished. Do not allow children to operate appliance.

Always ensure that no sporting or physical activities are carried out in close proximity to the appliance during use and while still hot.



## WARNING

Failure to comply with these instructions could result in a fire or explosion which could cause serious bodily injury, death or property damage.

Accessible parts may be very hot.

Keep young children away.

Any modifications to this appliance may be dangerous.

Do not move this appliance during use.

Turn off gas supply at the cylinder after use.

Read instructions before using the appliance.

Parts sealed by the manufacturer or their agent must not be manipulated by the user.

This appliance is only to be used and stored outdoors.

Never operate this appliance without a regulator.

Do not test for gas leaks with an open flame

If this information is not followed exactly, a fire causing death or serious injury may occur.

Do not store a spare gas cylinder under or near this appliance. Never fill the cylinder beyond 80% full.

If you smell gas

1. Shut off gas to the appliance at its source, if possible.
2. Extinguish any open flame.
3. Open hood.
4. If odour continues, immediately call your gas supplier or fire department.

Do not connect your appliance to a gas cylinder exceeding 9kg capacity.

Never connect an unregulated gas cylinder to your appliance.

Read carefully before assembling and operating your appliance.



## FOR YOUR SAFETY

- Do not store or use petrol or other flammable liquids in the vicinity of this or any other appliance.
- Keep the gas hose away from hot surfaces and protect from dripping grease. Avoid unnecessary twisting of hose. Visually inspect the hose prior to each use for cracks, excessive wear or other damage. Replace the hose if necessary.
- Never test for gas leaks with a lit match or open flame. Never light appliance with door closed or before checking to ensure the burner tubes are fully seated over gas valve orifices.
- Never alter or modify the regulator or gas supply assembly.
- Ensure the appliance is set up on a level and stable surface.
- Do not move the appliance while in use or when hot.

## GENERAL ASSEMBLY

### Connecting & Disconnecting to the Gas Source

Familiarise yourself with the general information and safety guidelines located at the front of this manual.

#### Check:

1. The cylinder is filled. A sloshing sound will be heard when shaken.
2. The burner controls are in the 'OFF' position

#### Connecting:

1. Ensure cylinder valve is in its full off position.
2. Check for any damage to either the cylinder connection or the hose. NEVER attempt to use damaged equipment.
3. When connecting the hose to the cylinder tighten the nut to a positive stop by hand or spanner.
4. Open cylinder valve fully. If a leak can be heard at either end of the hose turn cylinder off and tighten joint. Wait 5 minutes before re-testing and use a soapy water solution to check the joint. If bubbles appear, the connection will need to be re-tightened.

#### Disconnecting:

1. Ensure the burner control is in the 'OFF' position.
2. Ensure cylinder valve is in the full off position.

For storage and cylinder exchange, disconnect hose at the cylinder only, DO NOT disconnect hose from appliance.



### IMPORTANT

- Do not smoke when attempting to ignite the appliance.
- Always use protective gloves when handling hot components.
- Note: If for some reason, ignitor fails to produce a spark at the electrode, appliance can be lit by a long appliance match. With door open insert lighted match into match lighting hole positioned on the side of the burner chamber. Push and turn control knob to 'HIGH'. Burner ignition can be checked through this hole.
- The door must be in the open position for lighting.
- Do not leave the appliance unattended when alight.

## LIGHTING PROCEDURE

### Burner Operation & Ignition System Check

1. Turn the control knob clockwise to "OFF" position.
2. Connect the regulator to the gas bottle. Turn the gas supply "ON" at the cylinder. Check with the use of soapy water for any gas leakage between the bottle and the regulator
3. Open the door then push down the control knob and keep pressing whilst turning anti-clockwise to the "HIGH" (a clicking sound is heard), this will light the burner. If the burner does not light, repeat this process.
4. If the burner still does not light, turn the control knob to 'OFF' wait 5 minutes and repeat step 3.
5. Adjust the heat by turning the knob to the High/Low position.

#### AUS Standard POL Regulator

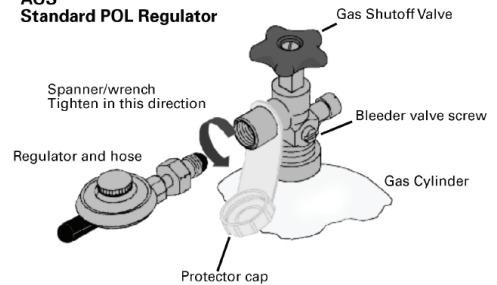

6. To turn the appliance 'OFF', turn the cylinder valve to the 'OFF' position and then the control knob on the appliance clockwise to the 'OFF' position.

### Ignition System Check

Problem: Burner will not ignite	
Possible Reason	Solution
Valve on cylinder is closed	Open valve on cylinder
Control knob is off	Turn knob to high when lighting
Igniter is faulty	Use a long match

## OPERATING INSTRUCTIONS

### Smoking

1. Carefully place a handful of flavouring wood directly into smoker box
2. Position the racks as required and place food in a single layer with space between each piece. This will allow smoke and moist heat to circulate evenly around all pieces of food.
3. Always use a meat thermometer to ensure food is fully cooked before removing from Smoker.
4. After cooking, allow Smoker to cool completely then follow instructions in the “Care & Maintenance” sections of this manual.

### Adding Flavoured Wood During Cooking

1. Stand back and carefully open bottom draws.
2. Add flavoured wood using long tongs.
3. Close the draw and allow food to continue cooking.

### Flavouring Wood Chips

To obtain your favourite smoke flavour, experiment by using chunks, sticks or chips of flavour producing wood such as hickory, mesquite or cherry. Most fruit or nut tree wood can be used for smoke flavouring. Do not use resinous woods such as pine as it will produce an unpleasant taste.

Note: Do not use man made timbers like MDF, chipboard due to resins used in manufacture.

Wood chunks or sticks 7.5 - 10cm long and 1.25 - 2.5cm thick work best. Unless the wood is still green, soak the wood in water for 20 minutes or wrap each piece in foil and tear several small holes in the foil to produce more smoke and prevent the wood from burning too quickly. A lot of wood is not required to obtain a good smoke flavour. A recommended amount is 3-4 wood chunks or sticks. Experiment by using more wood for stronger smoke flavour or less wood for milder smoke flavour.

Also suitable are flavouring pellets, these do not need to be soaked and can be used straight from the box. Use about 2 handfuls of the flavouring pellets.

## Technical Specifications

Gas Type	Injector Size	Total Gas Consumption	Gas Pressure
ULPG	Ø 0.90mm	10.5 MJ/h	2.75 kPa

## ADDING WATER OR WOOD DURING COOKING

Additional flavouring wood should not have to be added during the cooking process, however it may be necessary when cooking very large pieces of meat. Follow the instructions and cautions below to avoid injury while adding water and/or wood.

### Adding Water

1. Wearing oven mitts carefully open the top drawer.
2. Carefully add the water or liquid to the pan.
3. Carefully close the draw.

### Adding Wood

1. Wearing oven mitts carefully open the bottom drawer.
2. VERY HOT!! Lift the lid off.  
Note: Do not put on any combustible surface.
3. Carefully add around a handful of wood chips/pellets.  
Note: Wood chips must have been soaked in water for 20 minutes before being added.
4. VERY HOT!! Place lid back on smoker box.
5. Carefully close the draw.

## COOKING TIPS

**NOTE:** If your looking you're not smoking!

For best results leave door closed. Smoking is a slow process.

- Variations in flavour can be achieved by adding wine, soft drinks, herbs, spices, bits of citrus peel, fruit juice, onion or marinades to the water bowl as well as some water.
- Brush poultry and naturally lean meats with cooking oil, butter or margarine before cooking.
- Meat should be completely thawed before cooking.
- When cooking more than one piece of meat, the cooking time is determined by the largest single piece being cooked.
- The meat bastes itself while cooking in the Smoker. No basting or turning is necessary after the meat is placed on the rack. For added variety, barbecue sauce or marinade may be applied on meat before placing on rack.
- Always use a meat thermometer to determine if food is done. Many variables (outside temperature, proximity of food to heat source, etc.) will affect actual cooking times. When using a meat thermometer, place probe mid-way into the thickest part of the meat, making sure that it does not touch any fat or bone. Allow five minutes for the thermometer to properly regulate temperature.

### Air Vent Adjustments

Smoking cabinet temperature is best controlled by varying the air vent openings.

The key to effective smoking it to check the temperature gauge on the door and adjust the air vents accordingly.

Opening the upper air vents helps to exhaust both heat and smoke which will allow the smoker to run cooler.

Whilst closing the upper air vents will help to increase the temperature.

Note: The dampers should never all be fully closed.



### IMPORTANT

Place the Smoker outdoors on a hard, level and non-combustible surface away from roof overhangs or any combustible material. Never use on wooden or other surfaces that could burn. Place the Smoker away from open windows or doors to prevent smoke from entering your house. In windy weather, place the Smoker in an outdoor area that is protected from the wind.

Never attempt to remove water bowl when hot.

Read all safety warnings and instructions carefully before operating your Smoker.

Caution: Before each use, check handles and support brackets to make sure they are securely fastened.

## RECIPE IDEAS

### Smoked Chicken

1 chicken  
50ml olive oil  
Juice of one lemon  
Salt & Pepper

Mix the olive oil and lemon juice together in a cup or ramekin and then rub over the skin and sprinkle with salt and pepper. Place the chicken onto the cooking rack and place it in the smoker at 80°C for 90 minutes per 1/2 kilo.

It's important to make sure the chicken is properly cooked so ensure the juices run clear when a skewer is placed in the meat or use a thermometer. Breast meat should be at 73°C and thigh meat at 80°C.

### Smoked Herb Chicken

1 (approximately 2Kg) whole chicken  
45g butter  
4g chopped fresh parsley  
6g chopped fresh oregano  
3g chopped fresh basil  
3g fresh chives, finely chopped

Preheat outdoor Smoker & Grill for low heat. Using hickory is a great option if you want additional flavour in the chicken.

Rinse chicken inside and out and pat dry. Loosen skin around the breast area.

Place three tablespoons of butter in various places under the skin. Mix herbs together and place half under the skin and the other half inside the chicken.

Cook chicken in Smoker & Grill for 5-7 hours. It's important to make sure the chicken is properly cooked so ensure the juices run clear when a skewer is placed in the meat or use a thermometer. Breast meat should be at 73°C and thigh meat at 80°C.

### Smoked Mussels

Steam required quantity of mussels open. Marinate in sweet chilli sauce for 4 – 24 hours with a little brown sugar added. Smoke for approximately 40 minutes at about 70°C.

### Smoked Mushrooms

4 cups mushrooms  
2 tablespoons lemon pepper  
2 tablespoons garlic powder  
Cut mushroom stems off and wash. Sprinkle lemon pepper and garlic powder lightly over mushrooms. Smoke at 80°C for 60 minutes.

### Hickory Smoked Trout

120g x 4 portions Trout  
Brown sugar  
Salt & Pepper  
2 handfuls Hickory chips  
Coriander

Fillet trout taking care to remove all bones.

Tie 2 fillets together with string, having placed a sprig of coriander inside each.

Sprinkle trout with the brown sugar, salt and pepper. Place Hickory wood pellets into Smoker and place seasoned fish onto the cooking rack.

Starting with a high heat of 80°C to get a strong scent of Hickory, then allow to cool down to 60°C. This results in a beautiful caramel colour and tender pink centres. When cooked, remove string and serve as required.

### Smoked Corn on the Cob

6 to 12 ears of corn with husks on  
1/2 cup olive oil  
1 bunch finely chopped spring onions (including tops)

Gently pull back the husks on each ear. Remove the silk but not the husks. Place the ears in a large pot and cover with water. Let sit for several hours.

Remove from water and brush each ear of corn with olive oil, then sprinkle about 2 teaspoons of spring onion over. Cover corn with husks.

Repeat with each ear of corn.

Prepare smoker. The ears of corn will need to smoke at 80°C for about 2 hours.

When finished, remove husks and eat.

### Smoked Bratwurst

500g to 1kg Bratwurst sausages  
2 handfuls smoking chips or pellets, your favourite flavour

Rinse and dry on paper towels each bratwurst sausage.

Place your favourite flavour smoking chips or pellets into smoker box and prepare the smoker.

Starting with a high heat of 90°C to get a strong scent of your favourite smoke.

Place bratwurst sausages onto the cooking rack, ensuring you do not damage the casings as this will allow the juices to escape. Cook for around 2 hours to 2 1/2 hours or till the centre of each bratwurst sausage is around 70°C to 80°C.

Remove from the smoker and serve.



## Smoked Salmon

140g x 4 portions Salmon

1 Cup / 120ml maple syrup

1 Tablespoon / 15ml Butter

Coarse Salt

2 handfuls smoking chips or pellets, your favourite flavour

Clean each fillet of salmon taking care to remove all bones and the skin.

Place in fillets in a shallow baking dish and pour maple syrup over the top, turn each fillet to coat evenly.

Sprinkle with salt, cover and refrigerate for 24 hours.

Place your favourite flavour smoking chips or pellets into smoker box and prepare the smoker.

Starting with a high heat of 90°C to get a strong scent of your favourite smoke.

Place seasoned fish onto the cooking rack and cook for around 1 1/2 hours to 2 hours.

When ready to remove the salmon from the smoker, prepare the butter in a small frying pan.

Place the fillets into the hot butter in the frying pan and cook gently for about 2 minutes per side.

Remove from the frying pan and serve.

## Smoked Barbecue Baby Back Ribs

Total Time: 3 hrs 30 mins

Active Time: 30 mins

Makes: 3 racks, about 45 ribs

### Ingredients

3 tablespoons salt

2 tablespoons packed dark brown sugar

2 tablespoons Mexican mild chili powder

2 - 3 tablespoons smoked paprika  
(depending on taste)

1 teaspoons freshly ground black pepper

1/2 teaspoon cayenne pepper

1 teaspoon ground cumin

1 teaspoon garlic powder

1/2 - 1 teaspoon ground mustard seeds (depending on taste)

3 full racks baby back pork ribs (about 1kg)

3 tablespoons vegetable oil

2 cups barbecue sauce

### Instructions

Remember you are smoking and this is a slow process. Also if you are looking then you are not smoking.

1. Combine the salt, sugar, and spices in a small bowl, using a fork to break up any chunks; cover and set aside for at least 15mins.
2. Pat the ribs dry with paper towels and place on a work surface. Remove the thin membrane attached to the underside of the ribs by doing the following: Flip the ribs over so they're bone-side up. Starting at the end of 1 rack, slide the tip of a paring knife between the membrane and the bone, then lift and cut through the membrane.
3. Rub the ribs all over with the vegetable oil, evenly sprinkle with the spice mix. Place the ribs on a baking sheet, cover with plastic wrap, and refrigerate for at least 30 minutes and up to 8 hours. When ready to cook, remove the ribs from the refrigerator and let them come to room temperature, about 30 minutes.
4. Prepare the Gasmate smoker as per the instructions, ensuring to use water in the water tray and your favourite smoking pellets/chips in the smoking box.
5. Place the ribs into the Gasmate smoker, ensuring 1 rack of ribs per cooking grate, bone side down.
6. Smoke for at least 45mins at around 65degs.
7. Once the smoke starts to die down. Slather some barbecue sauce on the rib racks.
8. Start to close some of the air vents and work the smoker up to around 90-100degs.
9. Cook the racks of ribs for a further 2 – 2 1/2 hours. Check for doneness by lifting up one end of a rib rack. The rack should bend slightly in the middle. If it does not bend, continue to cook, until it does bend.
10. Serve the ribs warm with extra sauce

## CARE & MAINTENANCE

- Wash cooking racks and water bowl with hot soapy water, rinse well and dry. Lightly coat cooking racks with vegetable oil or vegetable cooking spray.
- Clean inside and outside of Smoker by wiping off with a damp cloth. After cleaning, apply a light coat of vegetable oil or vegetable cooking spray to the interior surface of the smoker body, cooking racks and water bowl. This simple process will help reduce interior rusting.

Note: NEVER oil the smoker pan lid. This could cause fire.

Note: Smoke will accumulate and leave a residue in the top of your unit that may drip onto food during cooking. To minimize accumulation of residue, wipe off after each use.

- Never apply paint to the interior surface.
- Rust spots on the interior surface can be buffed, cleaned, then lightly coated with vegetable oil or vegetable cooking spray to minimize rusting.
- Always keep your Smoker covered when not in use to protect against excessive rusting and dust.

## Flash-Back

Spiders and small insects occasionally spin webs or make nests in the burner tubes during warehousing and transit. These webs can lead to a gas flow obstruction which could result in a fire in and around the burner tubes.

This type of fire is known as 'FLASH-BACK' and can cause serious damage to your appliance and create an unsafe operating condition for the user. Although an obstructed burner tube is not the only cause of 'FLASH-BACK' it is the most common cause and frequent inspection and cleaning of the burner tubes is necessary.

If fire occurs in and around the burner, immediately turn off gas at its source and turn the burner control to 'OFF', wait until the appliance has cooled, then clean the burner tubes and burner ports.

## Abnormal Operation

Any of the following are considered to be abnormal operation and may require servicing:

- Yellow tipping of the burner flame
- Burners not igniting properly
- Burners failing to remain alight
- Burners extinguished by doors
- Gas valves, which are difficult to turn

## Service

If the appliance cannot be adjusted to perform correctly it should not be used until serviced or repaired. Contact Sitro Group Australia for spare parts and service information.



### WARNING

- Always allow Smoker and all components to cool completely before handling.
- Cover and store Smoker in a protected area, out of reach of children.



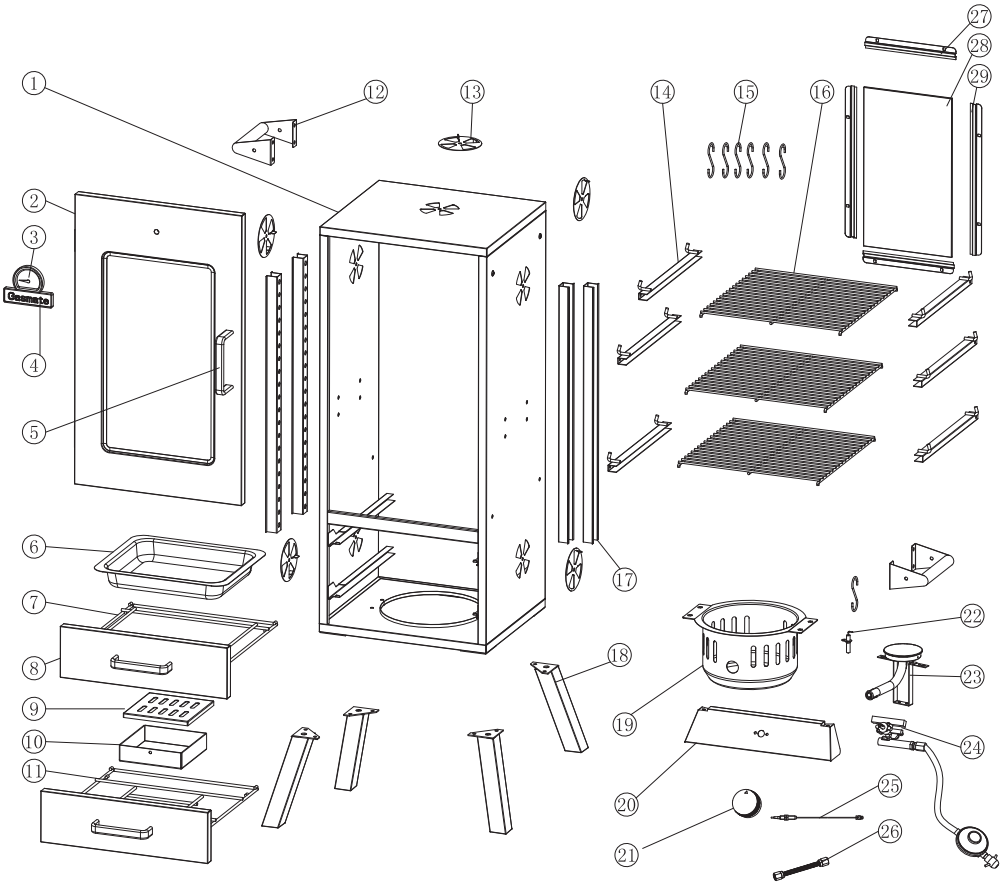

# COMPONENTS



No.	Description	QTY
1	Smoker Cabinet	1
2	Door	1
3	Temperature Gauge	1
4	Gasmate Bezel	1
5	Door Handle	3
6	Water Bowl	1
7	Water Bowl Rack	1
8	Drawer Assembly	2
9	Smoker Box Cover	1
10	Smoker Box Body	1
11	Smoker Box Rack	1
12	Side Handle	2
13	Air Vent	5

No.	Description	QTY
14	Rack Support	8
15	Hanging Hooks	6
16	Cooking Racks	3
17	Rack Beam	4
18	Leg Assembly	4
19	Burner Chamber	1
20	Control Panel	1
21	Knob	1
22	Electrode Pin	1
23	Burner	1
24	Manifold	1
25	Thermocouple	1
26	Corrugated Pipe	1

## HARDWARE

<b>A</b>  M6x12(25x)	<b>B</b>  M4x6(6x)	<b>C</b>  Ø6(5x)
<b>D</b>  M6(13x)	<b>F</b>  washer(6x)	

**IMPORTANT: Remove any transit protection material before use.**

TOOLS: Phillips Head Screwdriver  
Adjustable Spanner

## ASSEMBLY INSTRUCTIONS

### STEP 1

With the smoker cabinet upside down attach the legs as shown using six M6x12mm screws.

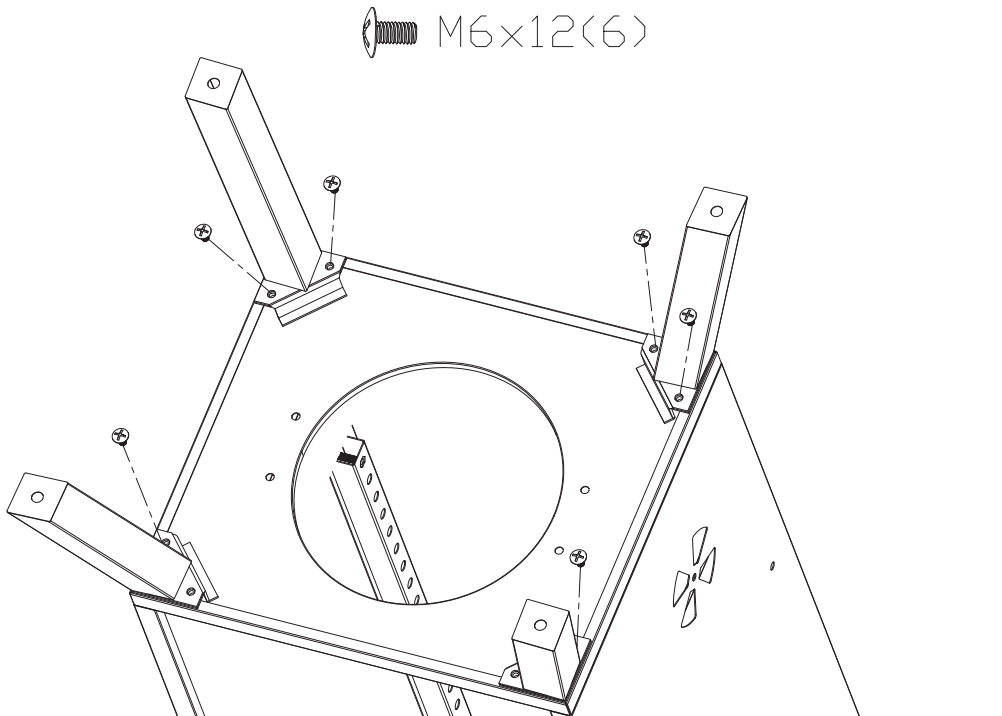

## STEP 2

Position the burner chamber ensuring the burner tube is located over the gas valve and secure from inside the cabinet with four M6x12mm screws, then attach the fascia panel using two M6x12mm screws.

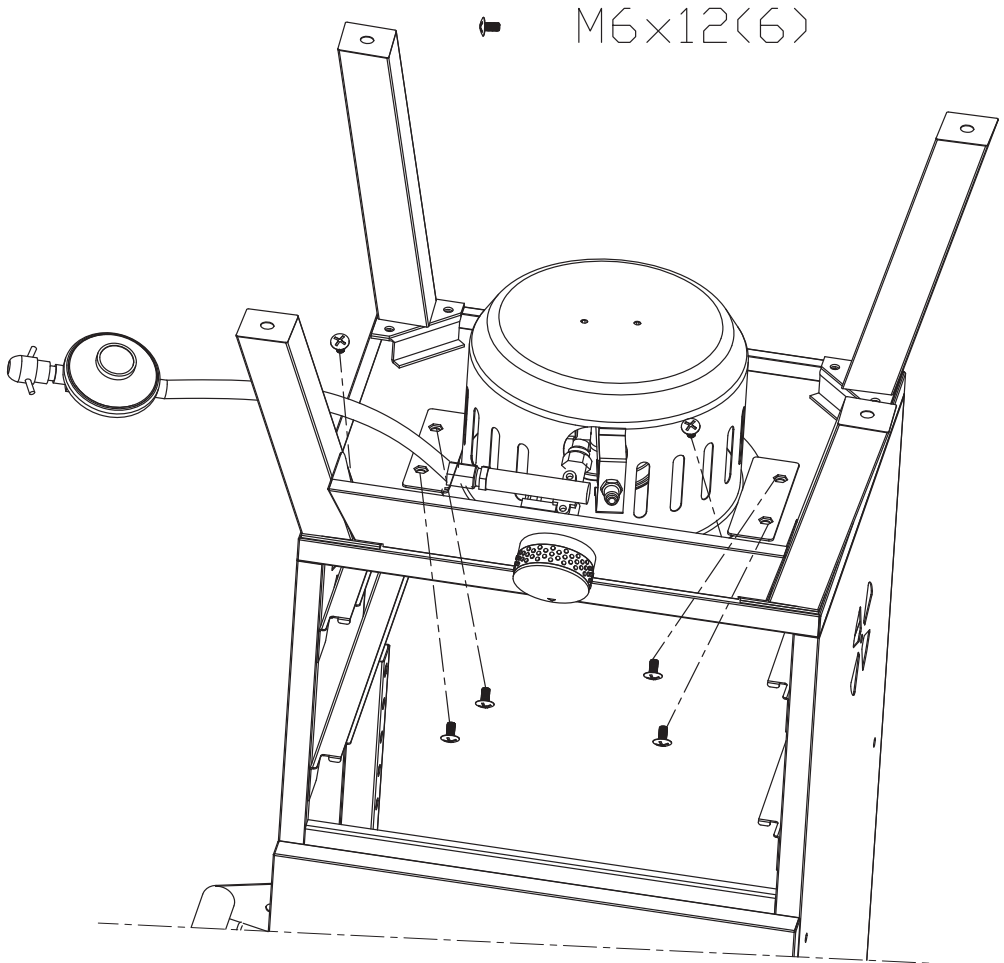

### STEP 3

Attach the handles using eight M6x12mm screws and nuts. Attach the five rotating air vents as shown using five M6x12mm screws, washers and nuts, ensuring that they cannot be fully closed.

 M6x12(13)

 M6(13)

 Ø6(5)

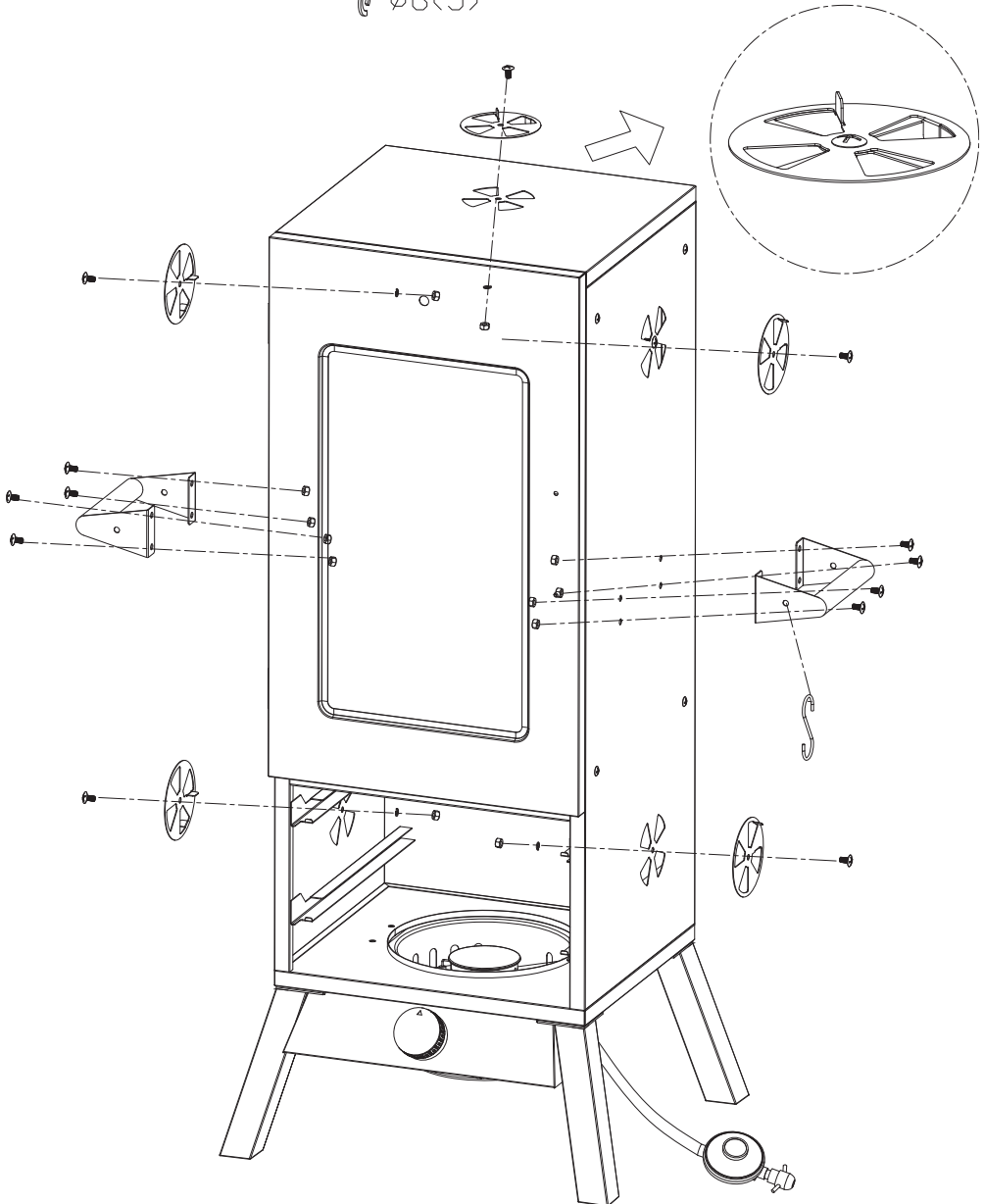

## STEP 4

Attach the drawer handles with fibre washers using four M4x6mm screws, then locate the Smoker Box in the bottom drawer and the Water Bowl in the top drawer.

 M4x6(4)

 washer(4)

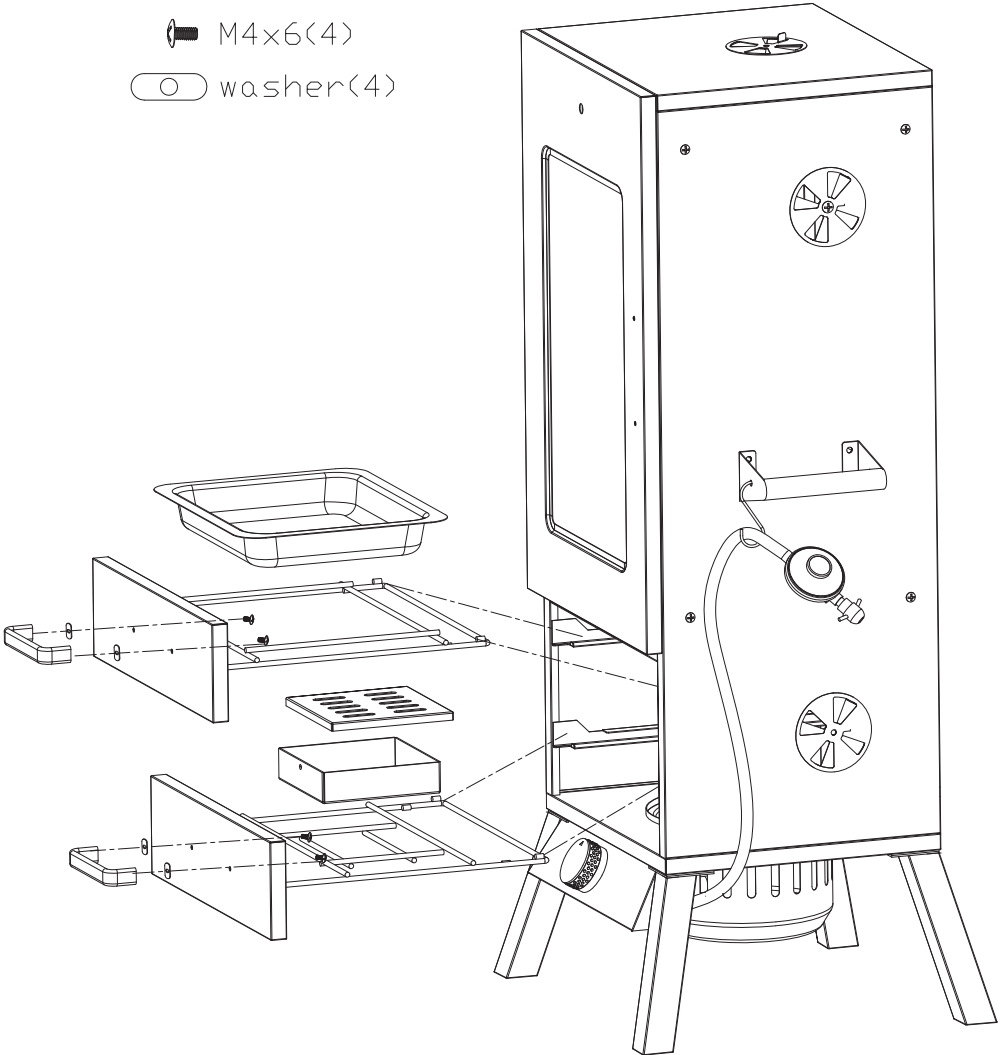

## STEP 5

Locate the rack supports as required on each side of the smoker cabinet or alternatively adjust the top rack then utilise the hanging hooks.

Note: One hanging hook is used to support the hose and regulator to the side handle when not in use.

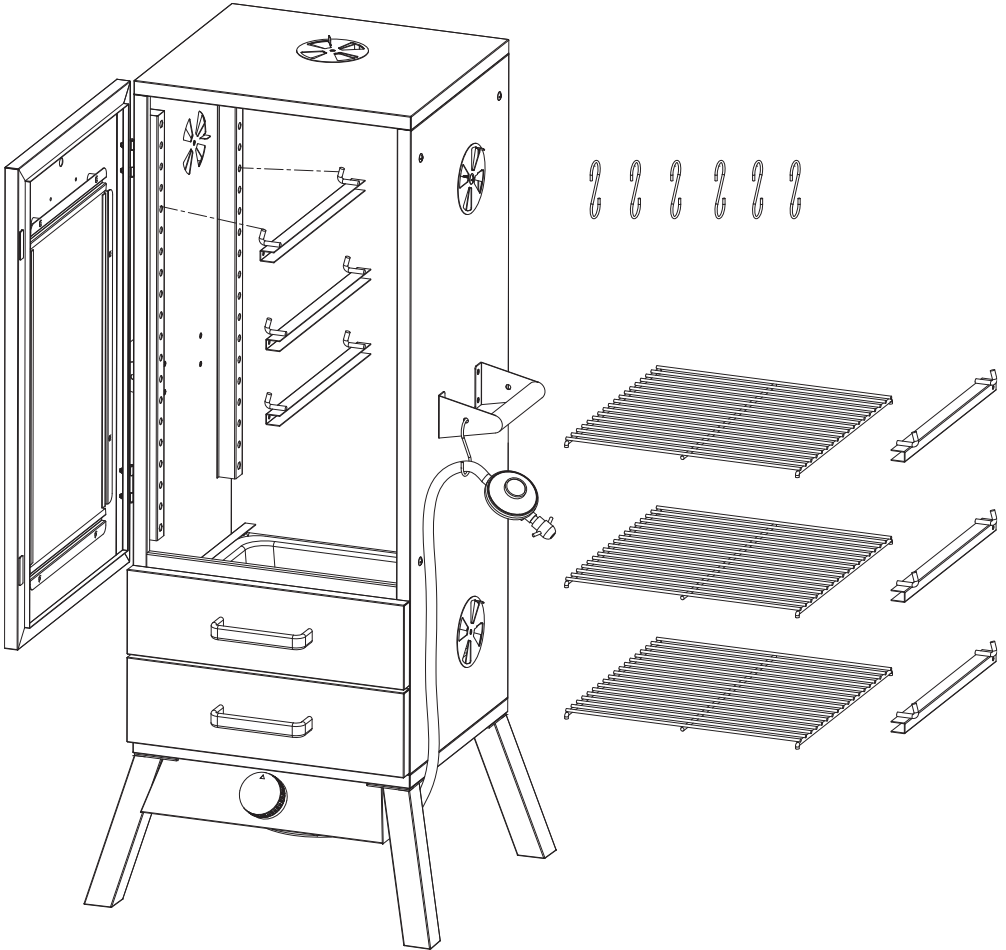



## STEP 6

Attach the temperature gauge bezel using the attached nut and the door handle using two M4x6mm screws.

 M4x6(2)

 washer(2)

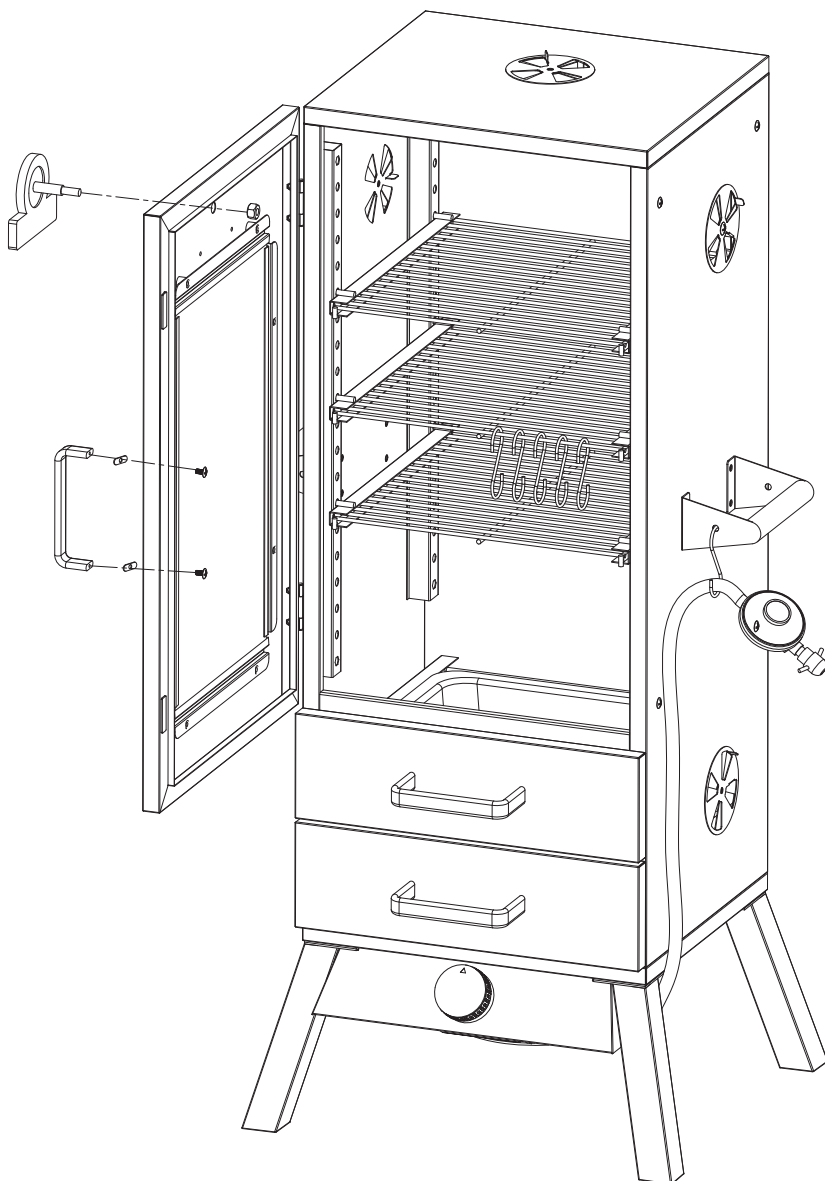

## STEP 7

The smoker is now ready to use. Please ensure you do a gas leak test before first use.

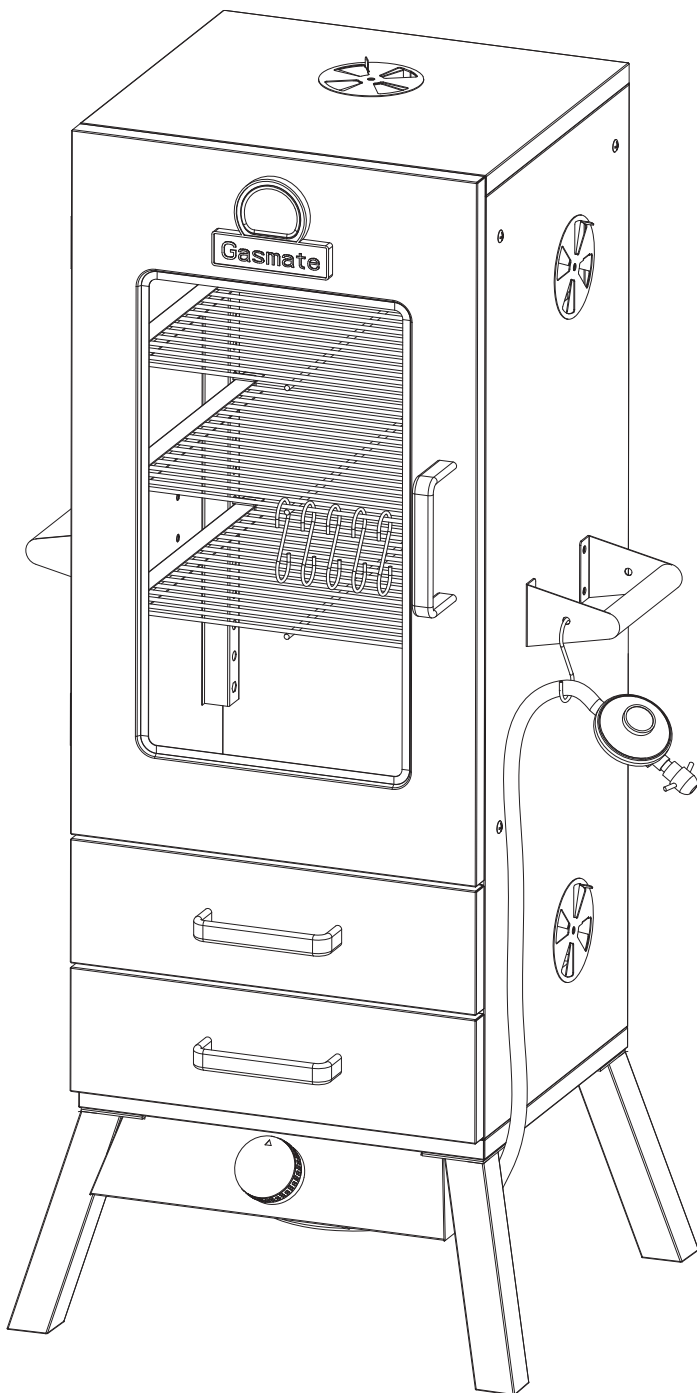

## SAFE APPLIANCE LOCATIONS

This appliance shall only be used in an above ground open-air situation with natural ventilation, without stagnant areas, where gas leakage and products of combustion are rapidly dispersed by wind and natural convection.

### Any enclosure in which the appliance is used shall comply with the following:

An enclosure with walls on all sides, but at least one permanent opening at ground level and no overhead cover (see Example 1).

Within a partial enclosure that includes an overhead cover and no more than two walls (see Example 2 & 3).

### Within a partial enclosure that includes an overhead cover and more than two walls, the following will apply:

at least 25% of the total wall area is completely open, and at least 30% of the remaining wall area is open and unrestricted (see Example 4 & 5).

In the case of balconies, at least 20% of the total wall area shall be and remain open and unrestricted.

## DIAGRAMMATIC REPRESENTATIONS OF OUTDOOR AREAS

The following figures are diagrammatic representations of outdoor areas. Rectangular areas have been used in these figures – the same principles apply to any other shaped area.

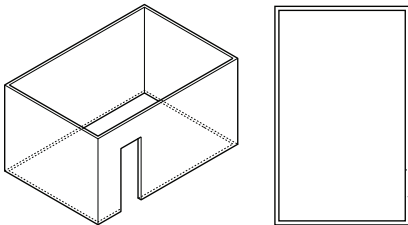

Outdoor Area - Example 1

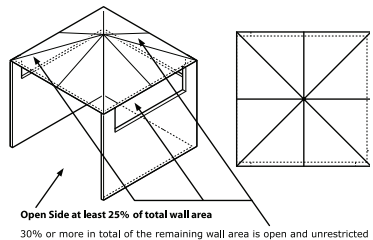

Outdoor Area - Example 4

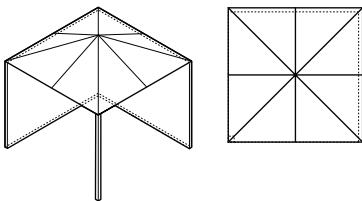

Outdoor Area - Example 2

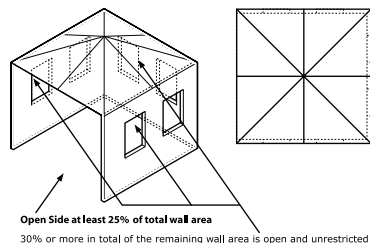

Outdoor Area - Example 5

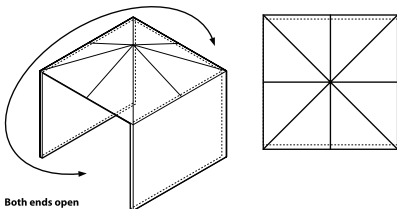

Both ends open

Outdoor Area - Example 3

**For any queries or assistance call**



**Customer Service**  
(Australia Only)

**1300 174 876**

Hours of operation:  
Monday to Friday 8.30am - 5.30pm EST

**Do not return to place of purchase.**  
Keep your purchase receipt, this will be required to  
make any claims under the 12 month warranty.

**Gasmate®**