



Specialist Deluxe Series II Built-In 4 & 6 Burner BBQ BQ8342B & BQ8362B



FEATURES

- Deluxe BBQ featuring vitreous enamel body and #304 stainless steel fascia
- #304 Stainless steel hood includes glass window and temperature gauge
- L.E.D. Control knobs
- Electronic ignition
- Cast iron rail burners
- Satin enamel cast iron grill and reversible hotplate
- Cast iron flame tamer with ceramic briquettes
- Operates on Universal L.P.G.
- Certified for conversion to Natural Gas
- IAPMO Oceana certified

Gasmate® is a registered trademark of: Sitro Group Australia Pty Ltd www.gasmate.com.au
Aber – Hamilton, N.Z. www.gasmate.co.nz

Important: Retain these instructions for future use.

GENERAL INFORMATION



IMPORTANT

Read these instructions carefully prior to use. Familiarise yourself with the appliance before connecting it to its gas container. Keep these instructions for future reference.



IF YOU SMELL GAS

1. Shut off gas to the barbecue at its source, if possible.
2. Extinguish any open flame.
3. Open hood.
4. If odour continues immediately call your gas supplier or fire department.

Gas Installation Codes

- Barbecues must be used in accordance with the installation requirements of your gas supply authority, or the Australian Standard AS 5601.
- Barbecues for use with bottled gas are labelled 'propane gas' or 'Universal L.P.G'.
- Barbecues for use with natural gas are labelled 'natural gas' and must be installed by an authorised person. Check the gas type sticker attached to the barbecue.

Clearances

Minimum Clearances from combustible materials must be:

Rear - 600mm Sides - 600mm Above - 600mm

Specifications

Barbecue specifications can be found on the data label attached to the barbecue body.

Hose connection thread is 1/4" B.S.P.

Hose & Regulator Safety

The regulator and hose assembly supplied with the barbecue are suitable for Propane Gas or Universal L.P.G. only.

A gas regulator adjusted to have an outlet pressure of 2.75kPa is supplied for connection to the propane gas cylinder. The pressure regulator and hose assembly supplied with the barbecue must be used. Replacement pressure regulators and hose assemblies must be those specified by the barbecue manufacturer.

When connecting the hose and regulator assembly to the gas cylinder, take care to avoid unnecessary twisting of the flexible hose.

After the assembly has been secured, turn on the gas and check for leaks by brushing a soap and water solution over all connections.

If you are unable to correct the leak by tightening the connections, turn off the gas and contact the supplier immediately.

Always ensure the barbecue is kept away from flammable materials and the gas cylinder clear of any heat source.

When changing over from an empty gas cylinder to a full one make sure this procedure is carried out in a well ventilated location, preferably outside, away from people and away from any sources of ignition; such as naked flames, pilot flames, electric heaters/equipment.

Gas Cylinder Use & Safety

This is a low pressure barbecue and must only be used with the regulator supplied. Your barbecue is designed for use with 4.5Kg or 9Kg propane gas cylinders certified to AS 2469.

The gas cylinder should be filled by a reputable gas supplier and visually inspected and re-qualified at each filling.

Always keep cylinder in an upright position.

Always close the cylinder valve when the barbecue is not in use.

Do not subject gas cylinder to excessive heat.

NEVER STORE YOUR GAS CYLINDER INDOORS.

If you store your barbecue indoors, ALWAYS disconnect the gas cylinder first and store the cylinder safely outside.

Cylinders must be stored outdoors in a well ventilated area out of reach of children, and must not be stored in a building, garage or any other enclosed area.



FOR YOUR SAFETY

- Failure to comply with these instructions could result in a fire or explosion which could cause serious bodily injury, death or property damage.

CAUTION: Accessible parts may be very hot.

Keep young children away.

Any modifications of this barbecue may be dangerous.

DO NOT move this barbecue during use.

Turn off gas supply at the gas cylinder after use.

Parts sealed by the manufacturer or their agent must not be manipulated by the user. This barbecue is only to be used and stored outdoors.

- Never operate this barbecue without a regulator.
- Do not test for gas leaks with an open flame.
- If this information is not followed exactly a fire causing death or serious injury may occur. Do not store a spare gas cylinder under or near this barbecue. This barbecue is only to be used and stored outdoors.
- If there is a leak on your appliance (smell of gas) immediately attempt to turn off the cylinder valve. Remove the appliance to a well ventilated location away from any ignition source. Only check for leaks outdoors using soapy water. DO NOT try to detect leaks using a flame.
- Check for leaks by brushing a soap and water solution over all connections. If you are unable to correct the leak by tightening the connections, turn off the gas and contact customer service immediately
- DO NOT replace the grill with an extra hotplate. The warranty will be voided and it violates the gas approval, the grill provides the ventilation needed for the BBQ to operate safely. It is not designed to be a solid hotplate device.

IF THERE IS A LEAK

- Turn the cylinder off.
- Ventilate the area to disperse gas.
- Check all connections.
- If leak persists, keep the cylinder upright. Keep skin away from any gas or liquid escaping from the cylinder.
- Keep the cylinder at least 20 metres away from any sparks or ignition sources, including electrical equipment, camera flashes, engines and motors.
- Disperse gas by encouraging maximum ventilation and spraying with a fine water spray.

IF THERE IS A FIRE

- If the fire is at the barbecue, turn the gas off at the cylinder. Smother the flames with a wet cloth, fire blanket or extinguisher using a fire extinguisher.
- If the fire is at the cylinder, or you can not get to the valve to turn the gas off, contact the fire brigade immediately
- Using a garden hose, direct the water to the middle of the cylinder to keep it cool. Try not to extinguish the flame. At least if the gas is burning, it won't be able to build up pressure and explode.

GENERAL INFORMATION

Location of your Barbecue

DO NOT use your barbecue in garages, porches, sheds, breezeways, or other enclosed areas. Your barbecue is to be used OUTDOORS. The barbecue is not intended to be installed in or on recreational vehicles and/or boats and should not be placed under any surface that will burn. Do not obstruct the flow of combustion and ventilation air around the barbecue housing.

Protect Children

Keep children away from barbecue during use and until barbecue has cooled after you have finished. Do not allow children to operate barbecue.

Always ensure that no sporting or physical activities are carried out in close proximity to the barbecue during use and while still hot.

Tools You Will Need

Adjustable spanner, Philips head screwdriver.

Check Barbecue for any Damage

Inspect barbecue parts as you proceed. Contact your supplier for assistance regarding replacement of any damaged or missing parts. Do not assemble or operate a barbecue that appears damaged. Barbecues for use with gas cylinders are labelled 'Propane Gas' or 'Universal L.P.G.'. Check labelling at the gas connection on your barbecue.



FOR YOUR SAFETY

- Do not store or use petrol or other flammable liquids in the vicinity of this or any other appliance.
- Do not store empty or full spare gas cylinders under or near this or any other appliance.
- Keep the gas hose away from hot surfaces and protect from dripping grease. Avoid unnecessary twisting of hose. Visually inspect the hose prior to each use for cracks, excessive wear or other damage. Replace the hose if necessary.
- Never test for gas leaks with a lit match or open flame. Never light barbecue with hood closed or before checking to ensure the burner tubes are fully seated over gas valve orifices.
- Never lean over cooking surface when lighting.
- Never alter or modify the regulator or gas supply assembly.
- This barbecue must not be used indoors.
- Only use in well ventilated areas.
- CARBON MONOXIDE HAZARD - USING THIS APPLIANCE IN AN ENCLOSED SPACE MAY CAUSE DEATH. DO NOT USE IN CARAVANS, TENTS, MARINE CRAFT, CARS, MOBILE HOMES OR SIMILAR LOCATIONS.
- This appliance shall only be used in an above ground open-air situation with natural ventilation, without stagnant areas, where gas leakage and products of combustion are rapidly dispersed by wind and natural convection.
- Ensure the barbecue is set up on a level and stable surface.
- Do not move the barbecue while in use or when hot. Remove the drip tray before moving.

CARE & MAINTENANCE

As with all appliances, proper care and maintenance will keep them in top operating condition and prolong their life. Your new gas barbecue is no exception. By following these cleaning procedures on a timely basis, your barbecue will be kept clean and working properly with minimum effort.

Flash-Back

Spiders and small insects occasionally spin webs or make nests in the burner tubes during warehousing and transit. These webs can lead to a gas flow obstruction which could result in a fire in and around the burner tubes. Cleaning with a soft brush before use and at least every six months is recommended.

This type of fire is known as 'FLASH-BACK' and can cause serious damage to your barbecue and create an unsafe operating condition for the user. Although an obstructed burner tube is not the only cause of 'FLASH-BACK' it is the most common cause and frequent inspection and cleaning of the burner tubes is necessary.

If fire occurs in and around the burner, immediately turn off gas at its source and turn the burner control to 'OFF', wait until the barbecue has cooled, then clean the burner tubes and burner ports.

Cleaning the Cooking Surface

After cooking, turn burner control to 'OFF' and let barbecue cool before attempting to clean the cooking surface. Before first use and periodically, it is suggested that you wash the cooking surface in a mild soap and warm water solution.

Care of Cooking Surface

Use and care of the cooking surface is important. Do not use pans on the cooking surface. Do not overheat the cooking surface with the hood down or no food on the cooking surface.

Cleaning the Drip Tray

To avoid fat or grease dripping from the barbecue remove and empty the drip tray after each use. Wait until the drip tray is cool to touch before disposing of contents.

The drip tray should be washed periodically in a mild detergent and warm water solution.









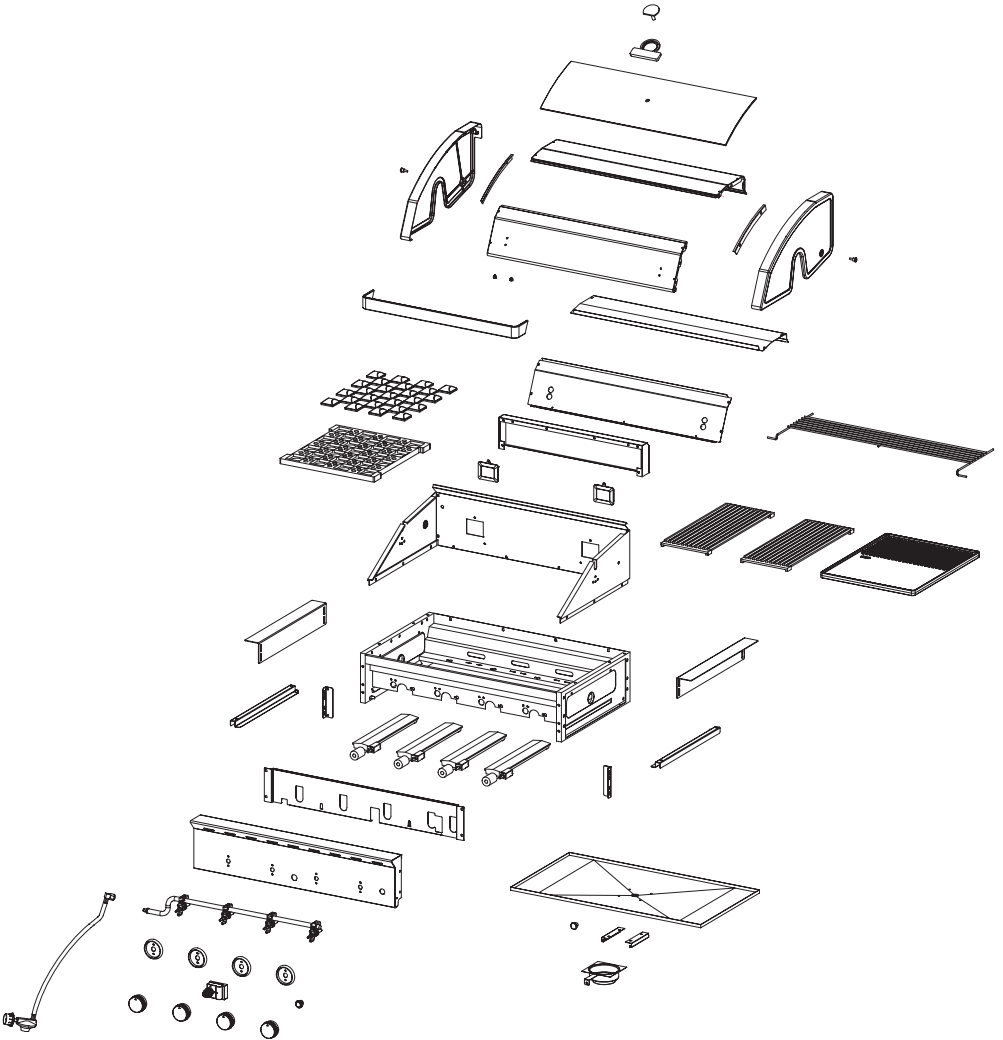

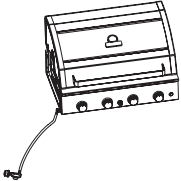
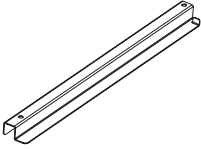

IMPORTANT

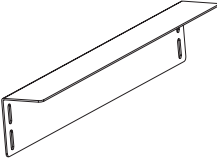
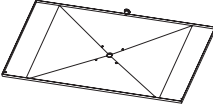
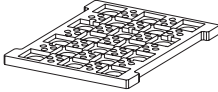
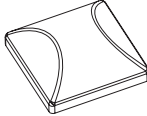
- Beware of spiders and wasps. Burner tube should be inspected and cleaned periodically.
- This appliance must only be serviced by an authorised person.
- To avoid any flare-ups, it is recommended that the drip tray be checked and emptied regularly. Contents of the drip tray may be very hot during cooking. If emptied during extended cooking extreme caution should be taken and direct contact by hand should be avoided at all times. Allow to cool completely before disposing of the contents.

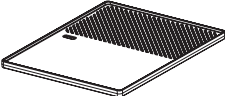
BQ8342B - EXPLODED DIAGRAM

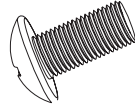
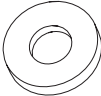

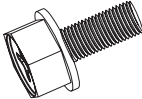





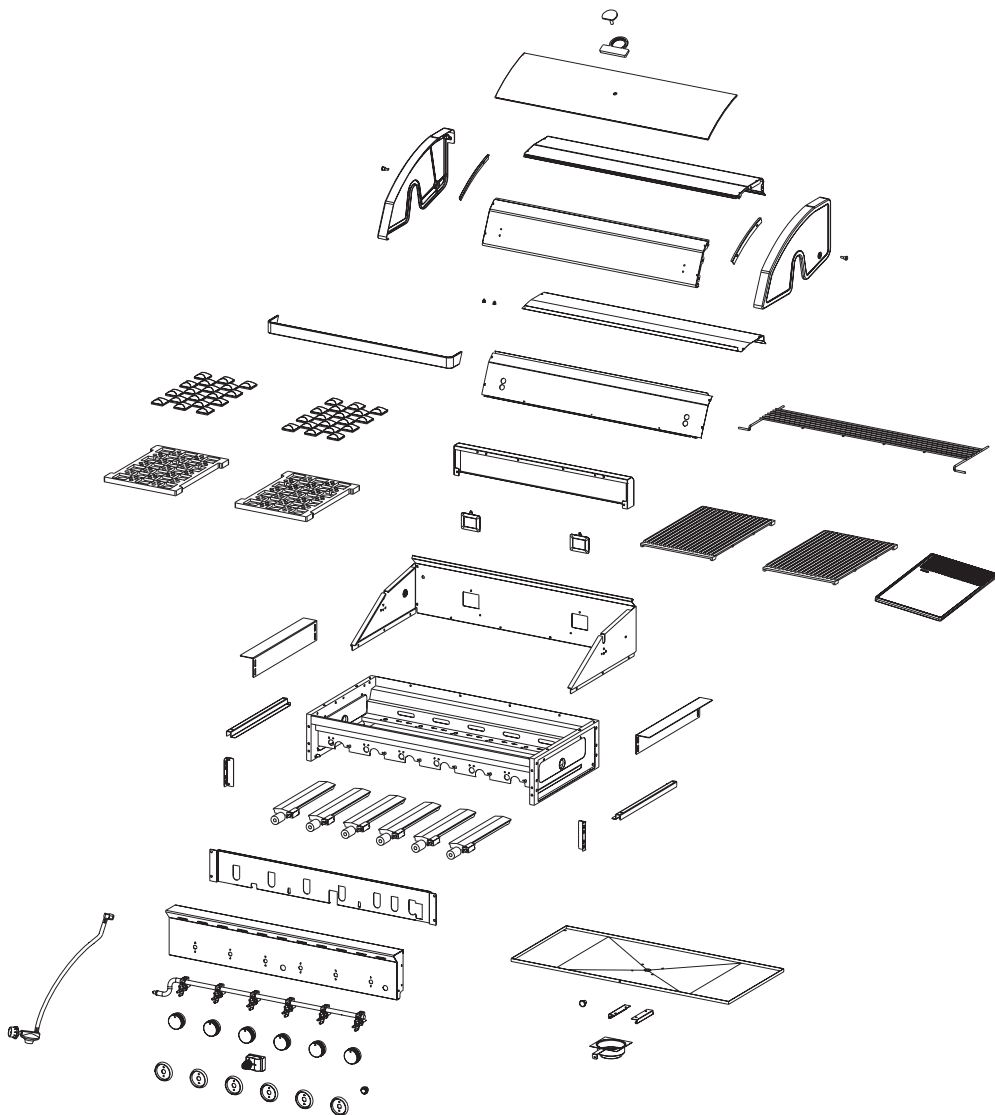

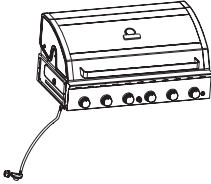
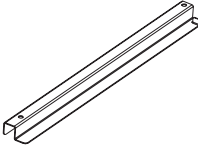

BQ8342B - PARTS LIST

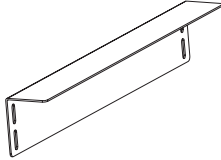
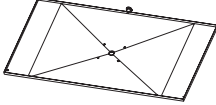
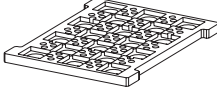
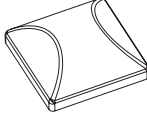
<p>1. Hood & Body Assembly 1pc</p> 	<p>2. Grease Tray Left Bracket 1pc</p> 	<p>3. Grease Tray Right Bracket 1pc</p> 	<p>4. Mounting Bracket 2pcs</p> 
<p>5. Grease Tray 1pc</p> 	<p>6. Flame Tamer 1pc</p> 	<p>7. Ceramic Stone 25pcs</p> 	<p>8. Grill Plate 2pcs</p> 
<p>9. Hot Plate 1pc</p> 	<p>10. Warming Rack 1pc</p> 	<p>11. M6*12 Screw 4pcs</p> 	<p>12. Washer - C (Ø6.4 x 14.5) 4pcs</p> 
<p>13. Nut M6 4pcs</p> 	<p>14. Bolt M6*12 8pcs</p> 	<p>15. Grease Cup 1pc</p> 	

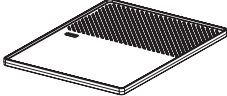
BQ8362B - EXPLODED DIAGRAM

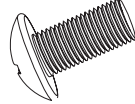
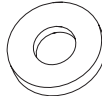

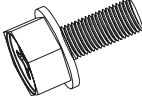
BQ8362B - PARTS LIST

<p>1. Hood & Body Assembly 1pc</p> 	<p>2. Grease Tray Left Bracket 1pc</p> 	<p>3. Grease Tray Right Bracket 1pc</p> 	<p>4. Mounting Bracket 2pcs</p> 
<p>5. Grease Tray 1pc</p> 	<p>6. Flame Tamer 2pcs</p> 	<p>7. Ceramic Stone 36pcs</p> 	<p>8. Grill Plate 2pcs</p> 
<p>9. Hot Plate 1pc</p> 	<p>10. Warming Rack 1pc</p> 	<p>11. M6*12 Screw 4pcs</p> 	<p>12. Washer - C (Ø6.4 x 14.5) 4pcs</p> 
<p>13. Nut M6 4pcs</p> 	<p>14. Bolt M6*12 8pcs</p> 	<p>15. Grease Cup 1pc</p> 	

ASSEMBLY INSTRUCTIONS

Remove any transit protection material.

Tools Required: Phillips Head Screwdriver & Adjustable Spanner.

STEP 1

Attach the grease tray left and right brackets (2,3) beneath the body left and right side panels by using 4pcs M6*12 screws (11), M6 nuts (13) and washer (12) as shown.

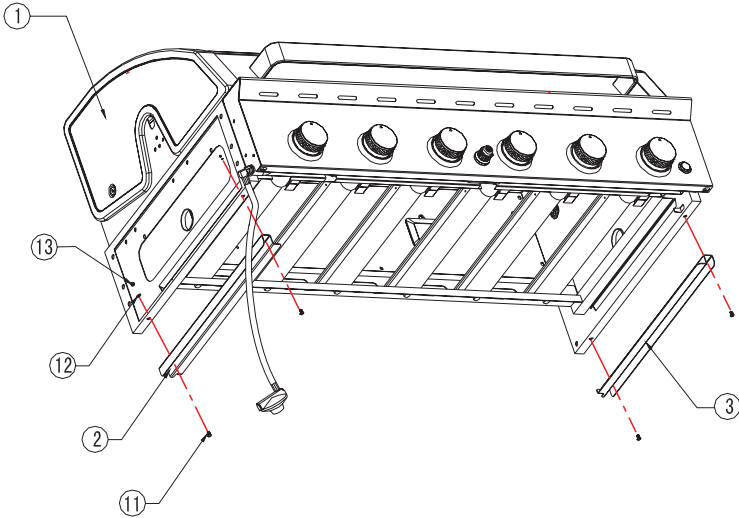

STEP 2

Attach the mounting brackets (4) as shown, onto the barbecue body (1) using 8pcs M6*12 bolts (14).

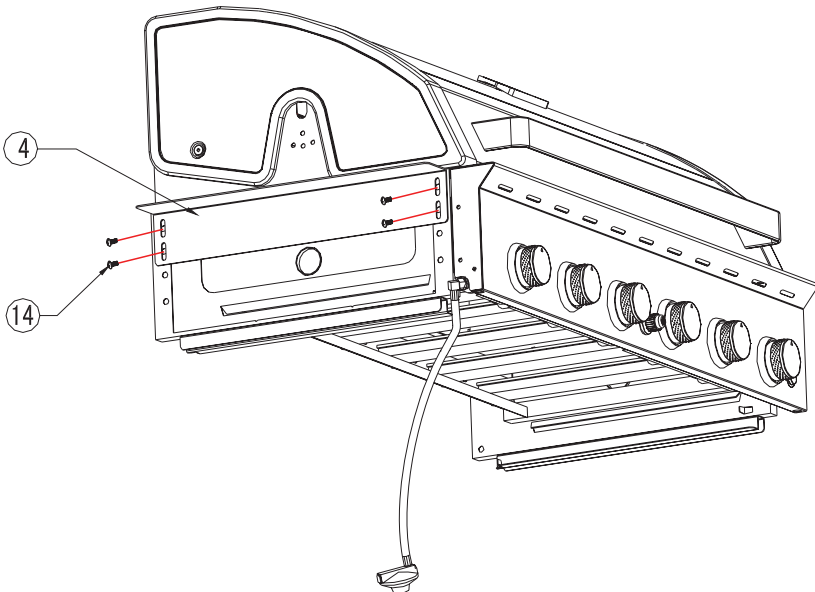

STEP 3

Slide the grease tray (5) into the grease tray bracket (2,3), then insert the grease cup (15) as shown.

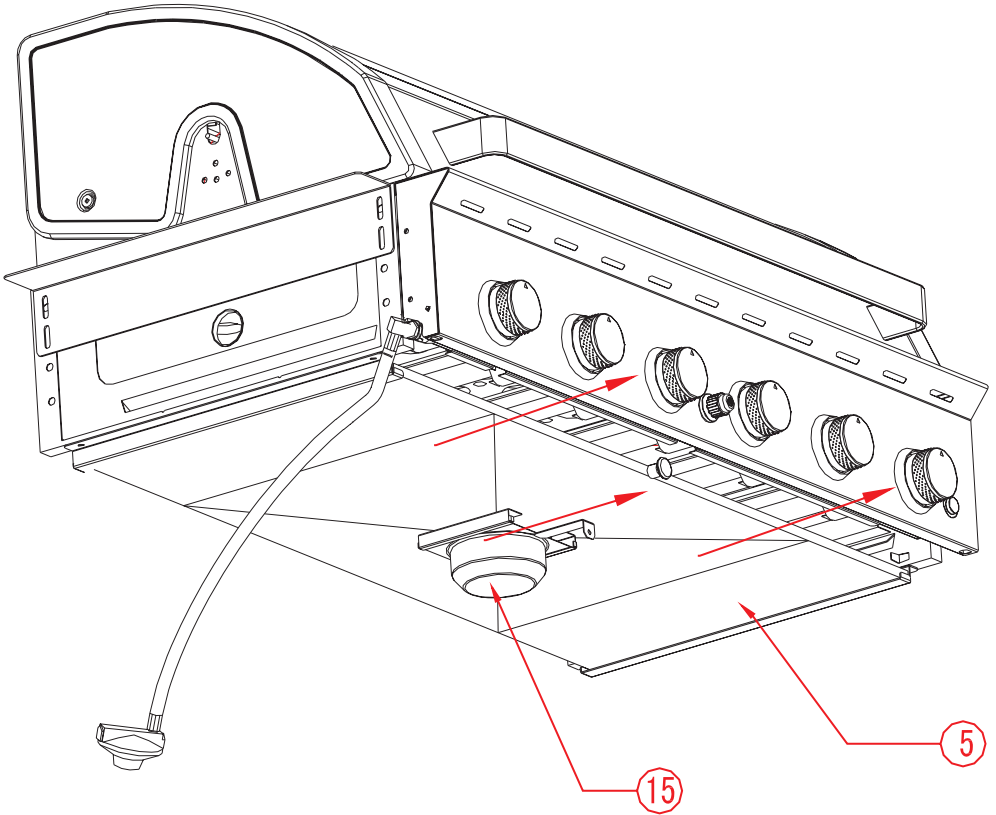

STEP 4

Place the Flame Tamers (6) on the top of left side 4 burners and place 36pcs Ceramic Stone (7) into the concave shape of flame tamer, place 2pcs Grill Plate (8), Hot Plate (9) and Warming Rack (10) into the body assembly as shown in the picture.

Note: The Grill Grates are located above the flame tamer.

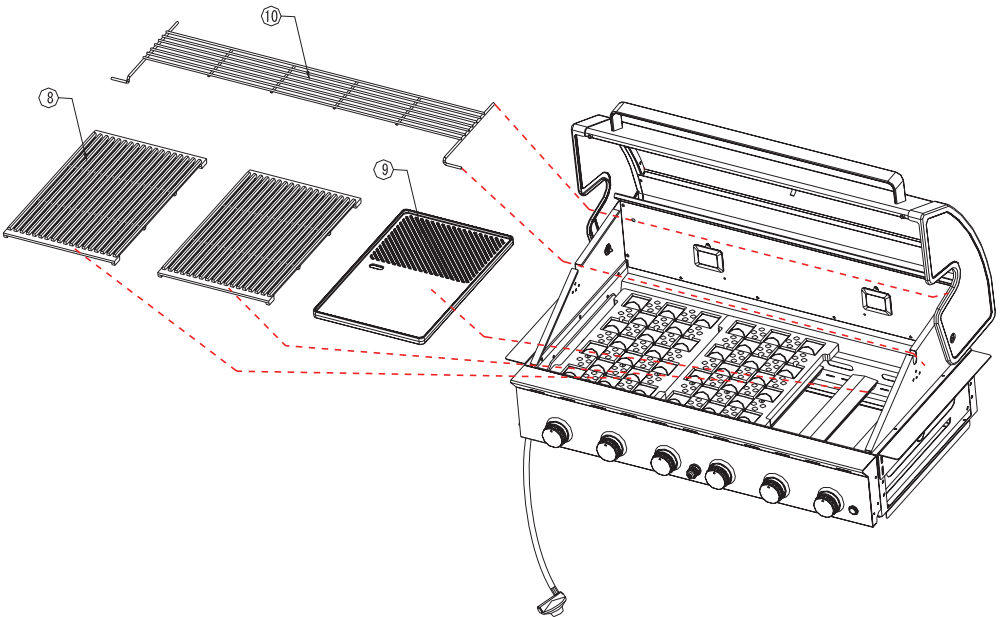
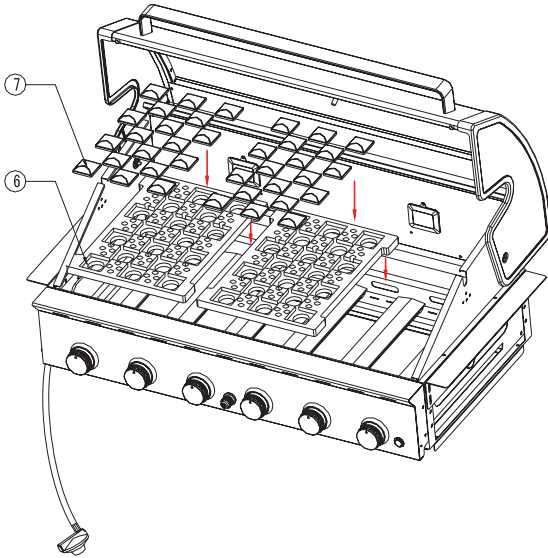

BUILT-IN GAS BBQ CLEARANCES

Built-In Barbecue Dimensions (4 Burner illustrated)

I.)

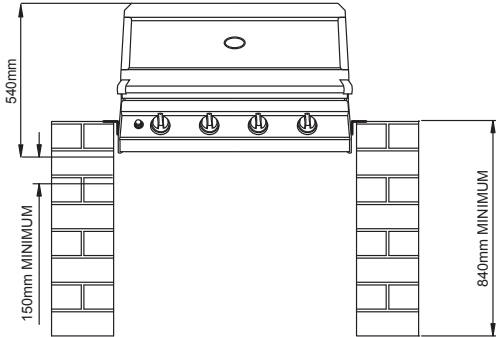

II.)

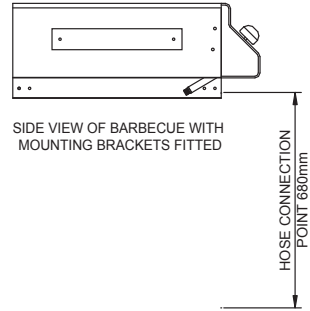

III.)

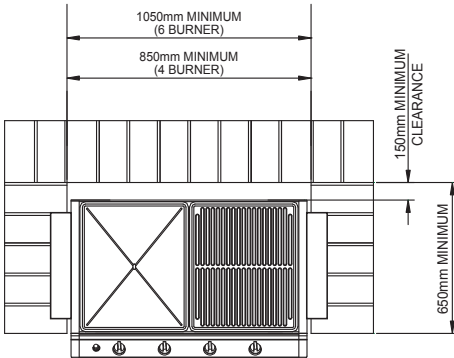

IV.)

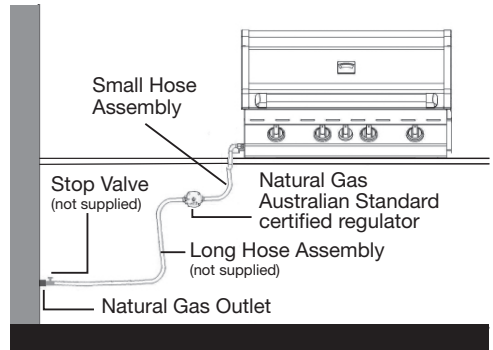

NOTE:

All installations must be as per appliance manufacturers specifications.
Minimum clearance to combustibles under fat tray is 150mm

NATURAL GAS CONVERSION

Installation, Operation & Maintenance Instructions

TO BE INSTALLED ONLY ON OR IN A NON-COMBUSTIBLE ENCLOSURE

Note: Recommended clearances must be maintained.

Tools Required

Adjustable spanner
Phillips head screwdriver

Gas piping

- (a) A minimum pipe diameter of 15mm is required for inlet piping. A lever operated shut-off valve should be installed within 1 metre of the appliance for servicing the unit.
(b) Where it is not practical to install solid tube AGA certified stainless steel braided hose can be installed. This hose assembly must comply with AS5601 Gas Installations, pipe sizing tables and shall not exceed 3 metres in length. The internal diameter of the hose must not be less than 10mm.
- Check with local and state plumbing and heating codes regarding sizing of the gas lines.
- All gas pipe connections must be sealed with a gas pipe compound resistant to Natural Gas.
- Installation of a drip leg if required in the gas supply line must conform to AS5601.
- When checking for gas leaks, do not use an open flame. Use a soap and water solution and check for bubbles indicating gas leakage.
- Installation of 1/8" NPT plugged tapping, accessible for test gauge connections, is required upstream of the gas supply connection.

SERVICING INSTRUCTIONS

Appliances should be serviced at least annually and servicing must only be carried out by a Licensed Plumber or Authorised Person.

Clean the Burner Ports and top with a Soft Brush. Inspect and clean all combustion air inlets, then replace the Burner ensuring it is firmly secured.

Minimum Clearance for Ventilation

Rear: 350 mm Side: 300 mm

NOTE TO INSTALLER

BBQ Burner and side burner, drill the injectors as per the data label specifications or contact customer service on 1300 174 876 to order an injector kit.

TEST OPERATION OF APPLIANCE BEFORE LEAVING.



WARNING

Improper installation, adjustment, alteration, service or maintenance can cause injury or property damage.

Read the instructions thoroughly before installing or servicing this equipment.

THIS APPLIANCE MUST NOT BE INSTALLED OR USED INDOORS.

**NATURAL GAS APPLIANCE.
TO BE INSTALLED ONLY BY AN AUTHORISED PERSON.**

THE AUTHORISED PERSON WILL PROVIDE A CERTIFICATE OF COMPLIANCE.

A suitable Australian Standard approved natural gas pressure regulator must be installed in the pipeline and be set at 1 kPa.

SAFE APPLIANCE LOCATIONS

This appliance shall only be used in an above ground open-air situation with natural ventilation, without stagnant areas, where gas leakage and products of combustion are rapidly dispersed by wind and natural convection.

Any enclosure in which the appliance is used shall comply with the following:

An enclosure with walls on all sides, but at least one permanent opening at ground level and no overhead cover (see Example 1).

Within a partial enclosure that includes an overhead cover and no more than two walls (see Example 2 & 3).

Within a partial enclosure that includes an overhead cover and more than two walls, the following will apply:

at least 25% of the total wall area is completely open, and at least 30% of the remaining wall area is open and unrestricted (see Example 4 & 5).

In the case of balconies, at least 20% of the total wall area shall be and remain open and unrestricted.

DIAGRAMMATIC REPRESENTATIONS OF OUTDOOR AREAS

The following figures are diagrammatic representations of outdoor areas. Rectangular areas have been used in these figures – the same principles apply to any other shaped area.

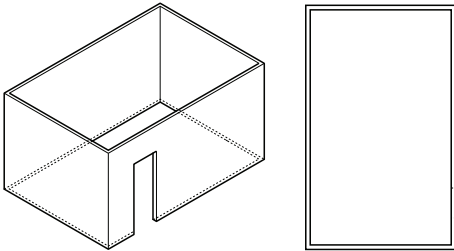

Outdoor Area - Example 1

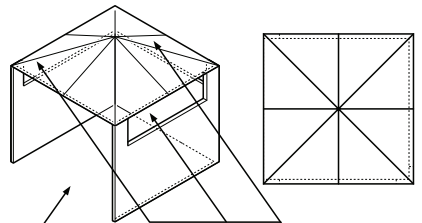

Open Side at least 25% of total wall area
30% or more in total of the remaining wall area is open and unrestricted

Outdoor Area - Example 4

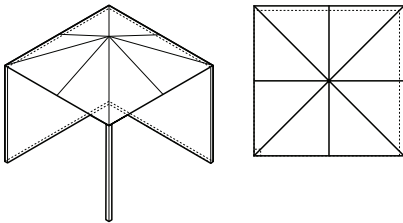

Outdoor Area - Example 2

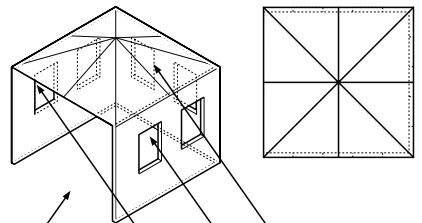

Open Side at least 25% of total wall area
30% or more in total of the remaining wall area is open and unrestricted

Outdoor Area - Example 5

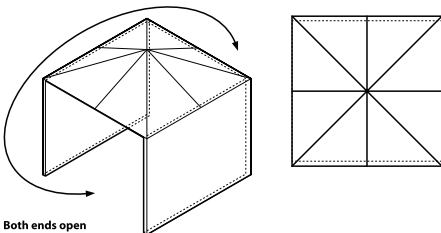

Both ends open

Outdoor Area - Example 3

BBQ SPECIFICATIONS

Overall Barbecue Dimensions

Model	Barbecue			Hood		
	Length	Width	Height	Length	Width	Height
4 Burner	830mm	590mm	200mm	830mm	575mm	300mm
6 Burner	1000mm	590mm	200mm	1000mm	575mm	300mm

Nominal Hourly Gas Consumption

Gas Type	Number of BBQ Burners	Injector Size BBQ Burner	Total Gas Consumption	Gas Pressure
ULPG	4	∅ 1.05mm	58.4 MJ/h	2.75 kPa
	6	∅ 1.05mm	87.6 MJ/h	2.75 kPa
	MJ/h each	14.6 MJ/h		
Natural Gas	4	∅ 1.7mm	54.4 MJ/h	1.0 kPa
	6	∅ 1.7mm	81.6 MJ/h	1.0 kPa
	MJ/h each	13.6 MJ/h		

For any queries or assistance call



Customer Service
(Australia Only)

1300 174 876

Hours of operation:
Monday to Friday 8.30am - 5.30pm EST

Do not return to place of purchase.
Keep your purchase receipt, this will be required to
make any claims under the 12 month warranty.

