



2000W OSCILLATING **ELECTRIC HEATER** WITH REMOTE CONTROL

Model No. EH431



2000W Quartz heating element

Designed for indoor and outdoor undercover use

Ideal for use under Verandas, Alfresco areas and Garage

The perfect solution to extend alfresco entertaining in the cooler months

Left/right oscillation

Easy installation

Remote control operation

Ultra slimline design with brushed aluminium body

Important: Retain these instructions for future use

SPECIFIC SAFETY INSTRUCTIONS

WARNING

This heater is not intended for use by persons (including children) with reduced physical, sensory or mental capabilities, or lack of experience and knowledge, unless they have been given supervision or instruction concerning the use of the heater by a person responsible for their safety. Children should be supervised to ensure that they do not play with the heater.

Do not use the heater in areas where there is a risk of explosion or fire from flammable gases. Ensure that the heating area is kept clear of combustible materials. Do not use the heater in damp areas, without suitable ventilation. This heater is not designed for use within 1m or above a water source. Do not place within one metre (1m) of any water source. Do not place directly below or above any power points or switches.

WARNING: Fire risk exists if this heater is covered by or positioned close to curtains or other combustible materials.

- This heater is intended for domestic/household use only.
- Always ensure that this heater is installed as per the requirements noted in Australian Standard AS/NZS 3000:2007.
- Always keep heater at least one metre (1m) from combustible materials.
- DO NOT locate this heater directly below or above the power supply socket or switch.
- DO NOT use this heater in either a bathroom or ensuite.
- DO NOT use a 3rd party timer, or programmable system with this heater.
- DO NOT clean the heater while the heater is on or plugged into the mains power supply.
- DO NOT touch any part of the heater while on, hot surfaces may burn.
- DO NOT use the heater as a dryer.
- DO NOT attempt to modify the heater, power cord, power plug or the supplied accessories in any way.
- DO NOT expose the heater to rain, water, or use in damp wet conditions.
- NEVER cover this heater.
- NEVER carry the heater by its power supply cord.
- NEVER use with the power cord coiled, bundled up or tied up. Always extend fully before use.
- NEVER use the heater if any part of it is damaged.
- Ensure that the heater is disconnected from the mains supply when installing, cleaning or moving.
- Ensure this heater is not left on when unattended.
- Ensure the heater is not used in areas where flammable gases are present, e.g. paint, petrol etc.
- Always turn the heater OFF at the unit switch and the power point switch when not in use for extended periods of time.
- Always allow the heater to cool, about one (1) hour after the heater has been turned off, before cleaning the heater.
- Always ensure that the power cord is fully extended and NOT in contact with any part of the heater.
- Always ensure that the heater is kept clean and free from dust.
- Only use this heater when securely mounted to the wall.
- Remove the remote control batteries when not using the heater for long time.
- Choose the same specification battery when replacing the remote control batteries, otherwise it may cause remote control not work, therefore affecting the normal use of the heater.
- The remote control function is line of sight and may not operate if something or someone is in the way of the signal.
- Replacing the batteries regularly is suggested to ensure the normal use and operation of heater.

If the mains connection plug or power cord becomes damaged it must be replaced with a complete assembly that is identical to the original, and this must be replaced by the manufacturer or an authorised service centre or similar qualified persons in order to avoid a hazard.



This logo/symbol means DO NOT COVER.

WARNING - In order to avoid over heating, DO NOT COVER the heater.

INSTALLATION, OPERATION AND MAINTENANCE INSTRUCTIONS

Safety

Before attempting to operate this heater, the following basic safety precautions should be taken to reduce the risk of fire, electric shock and personal injury. It is important to read the instruction manual and to understand its' applications, limitations and potential hazards associated with this heater.

This heater is not intended for use by persons (including children) with reduced physical, sensory or mental capabilities, or lack of experience and knowledge, unless they have been given supervision or instruction concerning the use of the heater by a person responsible for their safety. Children should be supervised to ensure that they do not play with the heater.

This heater is not designed for use within 1m or above a water source. It is important that you read, understand and follow these instructions very carefully. They are designed for the safety of yourself and others ensuring a long and trouble free service life from your heater. This electric heater complies with Australian and International standards and safety requirements. Repairs should only be carried out by qualified persons using original spare parts. Failure to do so may result in considerable danger to the operator.

SAFE OPERATION

Beware of Children and Pets

Children should not be allowed to touch or operate heaters or touch extension cords, if used. All heaters should be kept out of reach of children, preferably stored or locked in a secure cabinet or room when not in use.

Do not abuse or damage the power cord

Never yank or pull on the power cord to disconnect it from the mains supply socket. Never carry your heater by its' power cord. Keep the power cord away from heat, oil, solvents and sharp edges. Check the power cord regularly for any damage and if the power cord becomes damaged have it replaced by an authorised service facility.

Extension Cords and Reels

This heater is NOT designed to run off an extension cord. If you require an additional power point please have one installed by a qualified electrician.

The use of extension cords may cause power voltage loss which will result in damage to the motor this will NOT be covered under warranty.

Installation

Always ensure you select the correct fixing accessories which suit the particular material you are attaching to, if in doubt please discuss with your local retailer or local hardware store. This heater is not designed for use within 1m or above a water source. All installations must meet the requirements of Australia Standard AS/NZS 3000:2007.

Ensure that the heater is not positioned directly above or below a power point or switch.

This heater is not designed to be used with 3rd party timer or programmable system.

WARNING: Fire risk exists if this heater is covered by or positioned close to curtains or other combustible materials.

NOTE: When using this heater outside ensure that it is connected directly to an outdoor power point.

The electrical system of this heater must be connected with an automatic 30mA circuit breaker and/or residual current device (RCD). If uncertain have a qualified electrician check your electrical system before installation and/or use.

All electrical connections are made in a dry area.

Outdoor power points must be weatherproof and installed by a qualified electrician.

Sitro Group Australia Pty Ltd is not responsible for incorrectly chosen fixing accessories or any damage which may be caused by an incorrectly fitted heater.

ELECTRICAL DATA

IMPORTANT

This product is fitted with a sealed electrical connection plug that is compatible with the heater, the mains supply for Australia and meets the requirements of international standards. This heater must be connected to a supply voltage that is equal to that stated on the rating label. If the mains connection plug or power cord becomes damaged it must be replaced with a complete assembly that is identical to the original, and this must be replaced by the manufacturer or an authorised service centre or similar qualified persons in order to avoid a hazard. Always follow the Australian requirements for connection to the mains supply. If in doubt always consult a qualified electrician.

Technical Specification

Heater	EH431
Voltage	220-240V AC 50Hz
Input Wattage	2000W
Unit Weight	3.5Kg
IP Rating	IP65
Oscillation Angle	60° ± 5°
Tilt Angle from Horizontal	30° ± 5°
Remote Control Batteries (not supplied)	2 x AAA
Electrical Approval	GMA-505003-EA

Heater specifications can be found on the data label.

WALL MOUNTING HEATER & ASSEMBLY

NOTE: Remove any and all transit protection material.

If unsure about the type of fixings you require to mount your wall heater please discuss with your local hardware store.

- Ensure the fixing screws are at least suitable for 10kgs each.
- If fixing to a stud wall ensure all fixing screws are into timber.
- If no timber studs are available we would suggest installing a timber batten to attach to.
- The bottom of the wall heater body should be 1.8m above the floor.
- Do not position the wall heater directly above or below a power point or switch.
- Do not position wall heater in front of a power point.

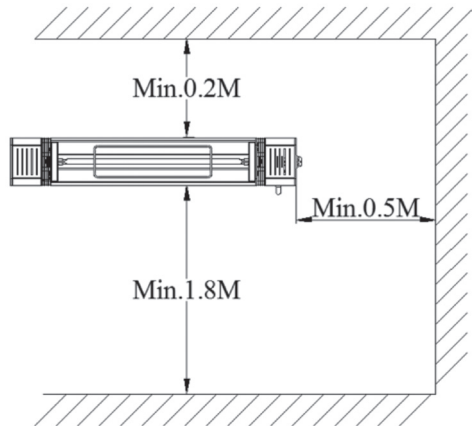

TO MOUNT THE WALL HEATER BRACKET

1. Take the wall bracket and select the position on the wall
2. Mark the holes for the wall bracket and drill
3. Using 4 suitable screws (not supplied) attach the wall bracket to the wall. Now assemble the wall bracket to the heater.

ASSEMBLE THE WALL HEATER

1. Have the heater with the OSCILLATION BOX on top and facing upwards.
2. Using the screws, washers and nuts assemble the wall bracket to the heater/oscillation box.
It is suggested to have the bolts from the top and the washers and nuts from the bottom.
3. Securely tighten the bolts and nuts.
4. Wall heater is now ready to mount to the wall using your wall fixings (not supplied).
5. Securely mount the wall heater to the wall.

REMOTE CONTROL

1. Remove back of remote control.
2. Insert batteries “AAA” x 2.
3. Slide back cover onto the remote control.

The remote control operates the left and right oscillation as well as the on/off wall heater function.

NOTE: The remote control will only work if the wall heater switch is ON and blue LED is glowing in front right panel. Refer to page 8 for how to use the remote control.

TO TILT HEAD

NOTE: Always ensure that the wall heater is switched off, disconnected from the mains power supply and is cold to touch. If heater has recently been used, please leave wall heater for about one (1) hour to cool before tilting head.

1. Loosen the 2 locking bolts, but DO NOT remove.
2. Tilt head down or up as required.
3. The head can be tilted through 30°, from horizontal
4. Hold heater head in position and tighten the 2 locking bolts securely.

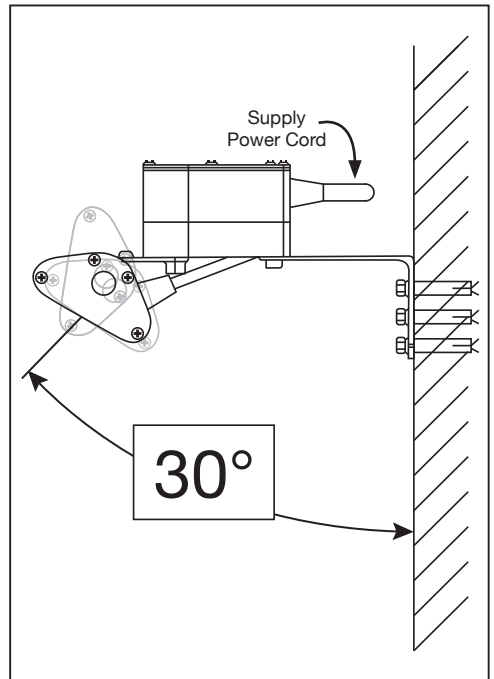
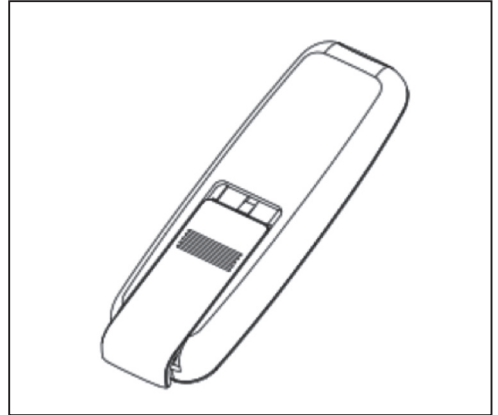

NOTE: Supply power cord not shown on images.

HEATER POSITIONING

1. Position heater at least 200mm from the eave lining or ceiling or wall at 90° to heater.
2. Position heater at least 1.8m above the floor.
3. Never position in front, above or below a power point.
4. If heater is facing another vertical surface, example – wall, the gap must be at least 1/2 metre.
5. Never mount heater within 1 metre of a water source, example – tap.

Note: Never mount heater into the wall. Only mount to the surface.

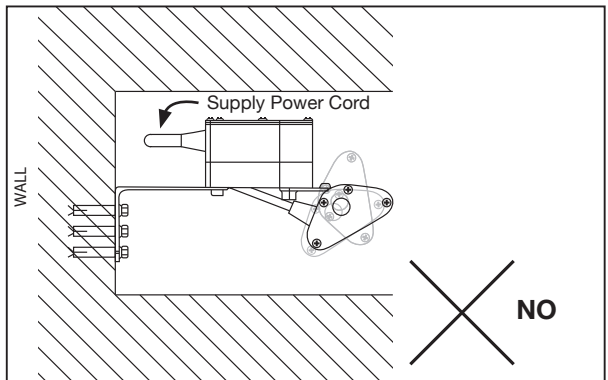
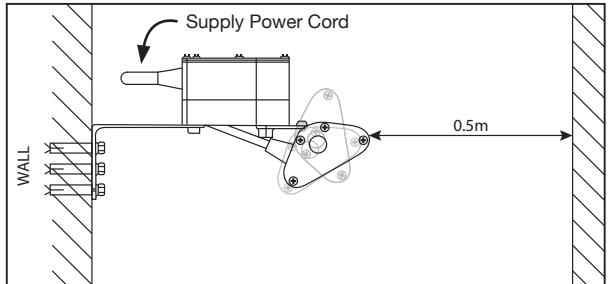
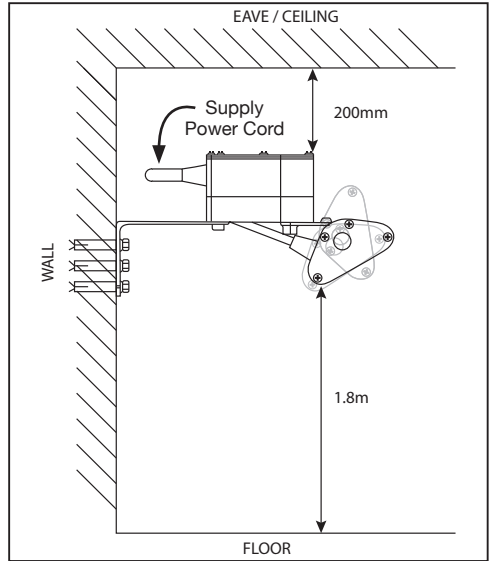

TO OPERATE

1. Plug into 240V AC wall socket and turn on.
2. Turn the heater switch on. This is the switch on the side of the wall heater, blue LED will glow in front right panel.
Note: all operations from here require the remote control.
3. Turn heater on via the remote control, see below.
4. The oscillation function is also controlled by the remote control and functions through a full 60°, which means 30° left and right.
5. Turn heater off via the remote control, see below.
6. Switch the wall heater switch off
7. Turn 240V AC wall switch off.

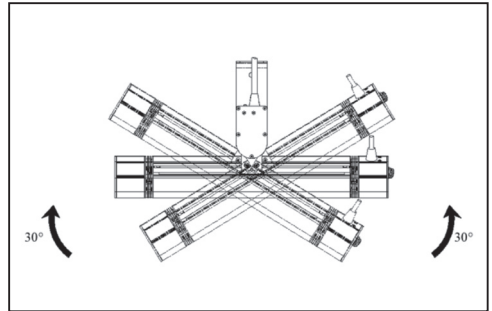

REMOTE CONTROL DIAGRAM

Your remote control will operate your heater to a maximum distance of 6m, line of sight.

TO TURN ON/OFF

Once blue LED is glowing in front panel.

1. To turn heater on, use the remote control, press ON (B).
The blue LED will change to red.
2. To turn heater off, use the remote control, press OFF (C).
The red LED will change to blue.

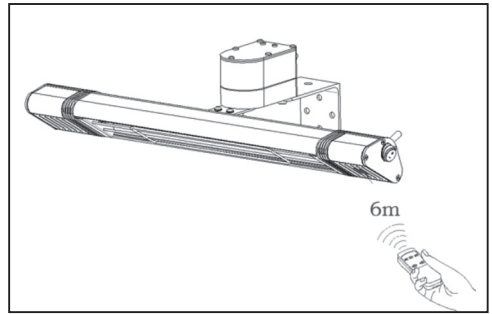

TO TURN OSCILLATION ON/OFF

Oscillation will only operate while the heater is on

1. To turn oscillation on, use the remote control, press ON (A).
 2. To turn oscillation off, use the remote control, press ON (A).
- The oscillation can be turned off at any time and the heater head will stay in the selected position.

CLEANING

Always ensure that the heater has been left for one (1) hour to cool before cleaning.

1. Turn off and disconnect from mains power, allow to cool.
2. Wipe unit over with a damp clean soft lint free cloth.
3. For stubborn marks you can use a mild dish washing solution on a damp clean soft lint free cloth.

NEVER allow water or a mild dish washing solution to enter or drip onto the heater.

NEVER use solvents, e.g. Petrol, Toluene, Methylated Spirits etc to clean the heater, as these will damage the surface finish and may cause a fire when unit is next used.

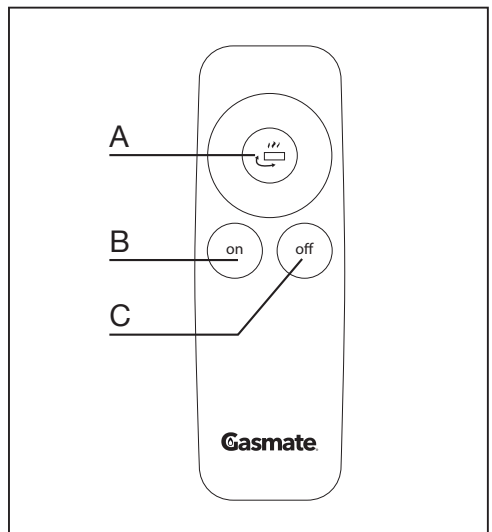

NOTE: Supply power cord not shown on images.

WARRANTY STATEMENT

GASMATE BARBEQUES & ACCESSORIES PRODUCT RANGE

SITRO GROUP AUSTRALIA (S.G.A.) warrants the purchaser of this product against defects in workmanship and materials for the following periods from the date of purchase:

For domestic use this table applies:

Stainless steel components	5 years (surface oxidization excluded)
Enamel components	5 years (chips excluded)
Powder coated components	1 year
Burners	3 years (surface rust excluded)
Cast iron cooking plates and burners	3 years (surface rust excluded)
Valves	3 years
Ignition	1 year
All other items	1 year

This warranty is not transferable to a subsequent purchaser if the product is sold by the original purchaser during the warranty period.

If a warranty fault appears within the warranty period, S.G.A. reserves the right to replace or repair the product.

In the event that S.G.A. chooses to replace the product, this original warranty will expire at the original date.

If the product includes various accessories or components, only the defective accessory or component will be replaced or repaired.

S.G.A. reserves the right to replace defective parts of the product with parts and components of similar quality, grade and composition where an identical part or component is not available.

Products presented for repair may be replaced by refurbished products of the same type rather than being repaired. Refurbished parts may be used to repair the products.

To make a warranty claim, first contact S.G.A.'s Customer Service Line on the contact number below.

The purchase receipt for this product is to be retained and must be presented if making claim under the terms of this S.G.A. warranty.

Warranty repairs are free of charge, provided the product is delivered to our Service Department at 33-35 Lionel Road, Mt Waverley, Victoria, 3149 or to one of our Authorised Service Agents.

If a warranty fault is found the freight cost will be credited to the owner.

If no fault is found the product will be returned and any costs associated with the service will be charged to the owner.

Products sent freight forward will not be accepted. In most cases the defective accessory or component only will need to be returned. The product or part of the product being returned must be adequately protected in a box.

S.G.A. will not be responsible for any in-transit loss or damage.

This warranty does not apply to any defect, deterioration, loss, injury or damage occasioned by or as a result of misuse or abuse, negligent handling or storage, normal wear and tear or if the product has not been installed and used in accordance with S.G.A.'s instructions, recommendations and specifications or if the product has been subjected to abnormal conditions. The warranty does not apply to blockages caused by insects or living organisms.

The warranty is void if there is evidence of the product being tampered with by unauthorised persons.

The warranty does not extend to installation or disconnection costs.

Our goods come with guarantees that cannot be excluded under the Australian Consumer Law. You are entitled to a replacement or refund for a major failure and for compensation for any other reasonably foreseeable loss or damage. You are also entitled to have the goods repaired or replaced if the goods fail to be of acceptable quality and the failure does not amount to a major failure. The benefits of this warranty are in addition to any rights and remedies imposed by Australian State and Federal legislation that cannot be excluded.

For warranty claims, service, spare parts or products information in Australia, please call SITRO GROUP AUSTRALIA Pty Ltd on the Customer Service Line 1300 174 876.

Register your Warranty online at
www.gasmate.com.au

A receipt or proof of purchase is required and must be kept for your records. Note: If you do not have internet access call our customer service team on 1300 174 876

CONTACT DETAILS

Sitro Group Australia Pty Ltd

33-35 Lionel Road, Mt. Waverley

Victoria 3149, Australia.

Tel (+613) 9543 9533

Fax (+613) 9543 9839

sales@sitro.com.au

For any queries or assistance call



Customer Service
(Australia Only)

1300 174 876

Hours of operation:
Monday to Friday 8am - 5pm EST

Do not return to place of purchase.

Keep your purchase receipt, this will be required to
make any claims under the 12 month warranty.

Gasmate®