



200L DUAL ZONE PREMIUM BAR FRIDGE

GMF200



- A stylish and functional addition to your outdoor space
- Beer section temperature 2°C - 5°C
- Red wine section temperature 8°C - 18°C
- Twin fan airflow between beer and red wine section
- Stainless steel exterior
- Triple glazed glass doors
- Designed for outdoor undercover use - IPx4 rated
- Front vents allow installation in outdoor cabinetry with minimal clearances
- Adjustable thermostat for temperature control
- Self closing doors with magnetic door seal
- Heated door reduces condensation
- Internal lights
- Adjustable shelves and racks
- Height adjustable feet
- Size: L90 x W50 x H85cm

Gasmate® is a registered trademark of:

Sitro Group Australia Pty Ltd
Aber – Hamilton, N.Z.

www.gasmate.com.au
www.gasmate.co.nz

Important: Retain these instructions for future use

PRODUCT DESCRIPTION

Inspect contents of the box to ensure all parts are included and undamaged

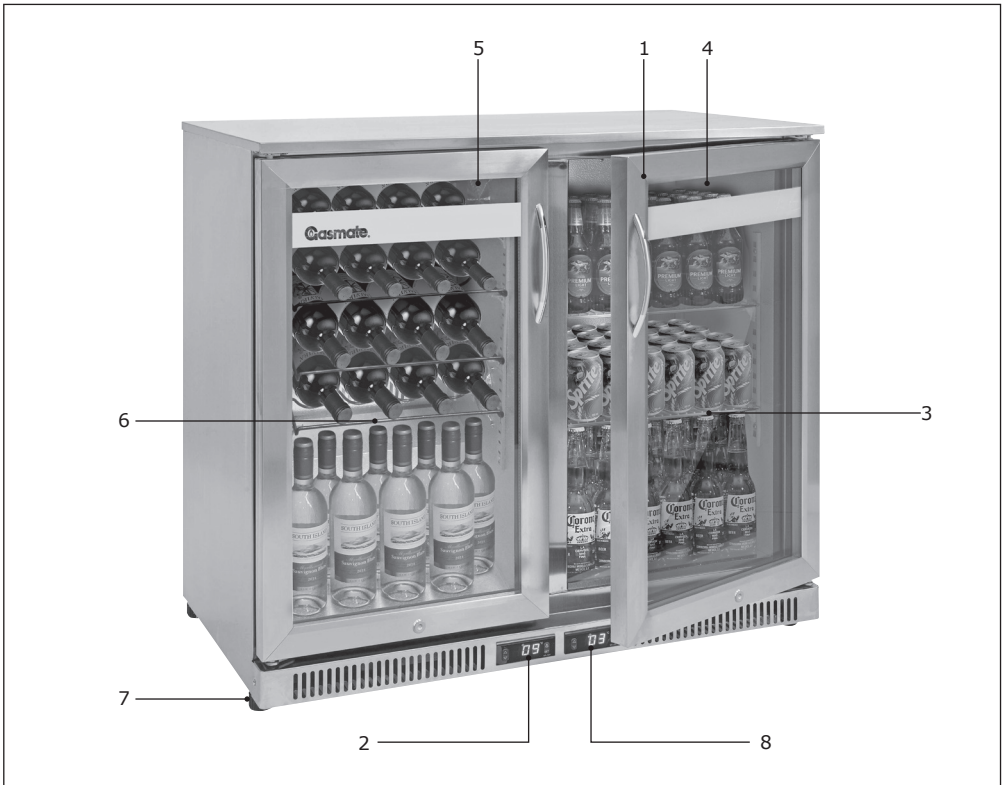

1. Triple glazed glass doors
2. Adjustable digital controller for wine side includes light switch
3. Adjustable beer shelves
4. Light is located at the top front of general dual zone bar fridge cabinet
5. Blue light switch is located at top front of wine side
6. Red wine shelves
7. Adjustable feet
8. Adjustable digital controller for general beverage side includes light switch

INSTALLATION, OPERATION AND MAINTENANCE INSTRUCTIONS

Electrical Installation

The electrical system of this dual zone bar fridge must be connected with an automatic 30mA circuit breaker and/or residual current device (RCD). If uncertain have a qualified electrician check your electrical system before installation and/or use.

Safety

Before attempting to operate this dual zone bar fridge, the following basic safety precautions should be taken to reduce the risk of fire, electric shock and personal injury. It is important to read the instruction manual and to understand it's applications, limitations and potential hazards associated with this dual zone bar fridge. This dual zone bar fridge is not intended for use by persons (including children) with reduced physical, sensory or mental capabilities, or lack of experience and knowledge, unless they have been given supervision or instruction concerning the use of the appliance by a person responsible for their safety. This dual zone bar fridge is not designed for use within 1m or above a water source. It is important that you read, understand and follow these instructions very carefully. They are designed for the safety of yourself and others ensuring a long and trouble free service life from your dual zone bar fridge. This electric dual zone bar fridge complies with Australian and International standards and safety requirements. Repairs should only be carried out by qualified persons using original spare parts. Failure to do so may result in considerable danger to the operator.

Safe Operation

Beware of Children and Pets

Children should not be allowed to touch or operate dual zone bar fridges or touch extension cords, if used. All dual zone bar fridges should be kept out of reach of children, preferably stored or locked in a secure room when not in use.

Do Not Abuse the Power Cord

Never yank or pull on the power cord to disconnect it from the mains supply socket. Never carry or move your dual zone bar fridge by it's power cord. Keep the power cord away from heat, oil, solvents and sharp edges. Check the power cord regularly for any damage and if the power cord becomes damaged have it replaced by an authorised service facility.

Extension Cords and Reels

This dual zone bar fridge is NOT designed to run off an extension cord. If you require an additional power point please have one installed by a qualified electrician.

The use of extension cords may cause power voltage loss which will result in damage to the compressor this will NOT be covered under warranty.



FOR YOUR SAFETY

NOTE: If using the dual zone bar fridge outside in an alfresco area ensure that it is directly connected to an outdoors power point.

Although this dual zone bar fridge is suitable for outdoor use ensure it is not left in the weather or in direct sunlight.

The electrical system of this dual zone bar fridge must be connected with an automatic 30mA circuit breaker and/or residual current device (RCD). If uncertain have a qualified electrician check your electrical system before installation and/or use.

All electrical connections are to be made in a dry area.

Outdoor power points must be weatherproof and installed by a qualified electrician.

Sitro Group Australia Pty Ltd is not responsible for incorrectly located dual zone bar fridges.

Specific Safety Instructions



WARNING

Do not use the dual zone bar fridge in areas where there is a risk of explosion or fire from flammable gases. Ensure that the area is kept clear of combustible materials. Do not use the dual zone bar fridge in damp areas, without suitable ventilation. This dual zone bar fridge is not designed for use within 1m or above a water source. Do not place within one metre (1m) of any water source.

Fire risk exists if this dual zone bar fridge is covered by or positioned close to curtains or other combustible materials.

- This dual zone bar fridge is intended for domestic/household use only.
- DO NOT use this dual zone bar fridge in either the bathroom or ensuite.
- DO NOT use a 3rd party timer, or programmable system with this dual zone bar fridge.
- DO NOT clean the dual zone bar fridge while the dual zone bar fridge is on or plugged into the mains power supply.
- DO NOT attempt to modify the dual zone bar fridge, power cord, power plug or the supplied accessories in any way.
- DO NOT expose the dual zone bar fridge to rain, water, or use in damp wet conditions.
- DO NOT expose the dual zone bar fridge to direct sunlight.
- If left in direct sunlight the dual zone bar fridge may not operate as designed.
- NEVER use with the power cord coiled, bundled up or tied up. Always extend fully before use.
- NEVER use the dual zone bar fridge if any part of it is damaged.
- Ensure that the dual zone bar fridge is disconnected from the mains supply when installing, cleaning or removing.
- Always turn the dual zone bar fridge OFF at the power point switch when not in use for extended periods of time.
- Always ensure that the power cord is fully extended.
- Always ensure that the dual zone bar fridge is kept clean and free from dust.
- Never use dual zone bar fridge with cracked/broken glass - replace glass before use.
- Only use this dual zone bar fridge on flat and level ground.
- Before you throw away your old dual zone bar fridge, take off the door, leave the shelves in place, so that children may not easily climb inside.
- Never allow children to operate, play with or crawl inside the appliance.
- This dual zone bar fridge is not designed for perishable foods. It is a drinks dual zone bar fridge.
- Adults and children should never sit or stand on the dual zone bar fridge as injury may occur.



WARNING

- When you dispose of your old dual zone bar fridges and freezers, remove any doors. Children can suffocate if they get trapped inside.
- This appliance contains insulation formed with flammable blowing gases. Avoid safety hazards by carefully disposing of this appliance.
- The appliance must be plugged into its own dedicated 220-240V, 50Hz AC electrical outlet.
- Ensure that the electric outlet is properly earthed to ground. Consult a qualified electrician if you are unsure.
- The electrical system of this dual zone bar fridge must be connected with an automatic 30mA circuit breaker and/or residual current device (RCD). If uncertain have a qualified electrician check your electrical system before installation and/or use.
- Do not use an extension cord or adaptor plug.
- Unplug the appliance before cleaning.
- Never unplug the appliance by pulling on the power cord. Always grip the plug firmly, and pull straight out of the receptacle to prevent damaging the power cord.
- Chose a location that is not too cold - the ambient temperature should be above 8°C.
- Chose a location that is not affected by direct sunlight.
- Chose a location that is not affected by rain.
- Put the appliance in a dry place, avoiding areas of high moisture or humidity.
- Don't put the appliance in direct sunlight.
- Don't put the appliance near stoves, fires or heaters.
- The appliance shall not be exposed to rain.
- Keep ventilation openings, in the appliance enclosure or in the built-in structure, clear of obstruction. Do not use mechanical devices or other means to accelerate the defrosting process. Do not use an electrical appliance inside the appliance.
- If power cord is damaged, it must be replaced by the manufacturer or its service agent or a similarly qualified person in order to avoid a hazard.

Protect from Moisture

Avoiding placing the dual zone bar fridge in a place where heavy moisture is present so as to minimise possibility of rusting of metal parts. The dual zone bar fridge should be kept out of water or direct sprayed water, failure to do this could cause poor performance and/or an electrical short could occur. Choose a location that is not affected by rain.

Protect from Heat

The dual zone bar fridge should be protected from excessive heat sources and out of direct sunlight.

Protect from Cold

The dual zone bar fridge should be protected from excessive cold weather and frosts. Suggested minimum ambient temperature should ideally be higher than 8°C.

Moving

When moving, the dual zone bar fridge cannot be reclined to more than 45°. Any greater angle may damage the cooling system.

Never move the dual zone bar fridge while it is plugged in and operating.

Once you have moved the dual zone bar fridge, leave standing in a level position for 2 hours so that the gas can settle.

Positioning

Ensure the sides, top and rear have at least 10mm clearance to ensure adequate ventilation.

Never cover the bottom front grill as this is required for correct ventilation.

After installation the appliance should be left for 2 hours before it is switched on in order to allow the refrigerant to settle.

Disposal of Old Appliances

The majority of components are recyclable, however there are also dangerous chemicals inside. To dispose of old dual zone bar fridges remove the doors and contact your local council for recycling options.

Electrical Installation

The electrical system of this dual zone bar fridge must be connected with an automatic 30mA circuit breaker and/or residual current device (RCD). If uncertain have a qualified electrician check your electrical system before installation and/or use.

IMPORTANT

Electrical Data

This product is fitted with a sealed electrical connection plug that is compatible with the dual zone bar fridge, the mains supply for Australia and meets the requirements of international standards. This dual zone bar fridge must be connected to a supply voltage that is equal to that stated on the rating label. If the mains connection plug or power cord becomes damaged it must be replaced with a complete assembly that is identical to the original, and this must be replaced by an authorised service centre. Always follow the Australian requirements for connection to the mains supply. If in doubt always consult a qualified electrician.

Note: Before using your dual zone bar fridge, unpack and correctly position. Once in position leave to stand for around 4-6 hours before turning on for the first time.

Glass Doors

These glass doors are heated to reduce the chance of condensation building up during times of high humidity and on very cold days.

These doors will be warm to touch. This is not a fault.

USING YOUR DUAL ZONE BAR FRIDGE

Temperature Control

- Your unit is provided with 2 digital controls. One for the general beverage section and a separate one for the wine section.

Note: During cold times, ambient temperature below 25°C the wine side may drop below your selected "warm" temperature. If this occurs you may need to turn the dual zone bar fridge off to totally off.



To Adjust Temperature Control

- Press "SET".
- Press the Δ up and ∇ down buttons to select the desired temperature. Number will flash.
- Once temperature is selected leave and allow flashing number to become solid.
- Allow dual zone bar fridge to cool for about 6 hours before filling.

Note: The two digital controllers work separately.

Turning Off Dual zone bar fridge

To turn off your dual zone bar fridge you will need to turn the power off at the power point and remove the power plug.

Internal Light

To turn lights on press  button once.

To turn lights off press  button again.

The lights in each section are operated separately by the digital controller under the specific door.

Note: The light in the wine section is coloured blue so as to not damage the wine.

Note: If mains power is tuned off the lights default setting is off.

To Replace Light

Note: Ensure dual zone bar fridge is turned off and the power lead disconnected from the power point.

- Dual zone bar fridge off and unplugged.
- Remove screws and clear plastic cover.
- Twist fluorescent tube out of holder.
- Fit new fluorescent tube.
- Fit clear plastic cover using screws, tighten.
- Turn dual zone bar fridge on.

STABILISING FEET

These are already fitted to your dual zone bar fridge. Before turning your dual zone bar fridge on please ensure your dual zone bar fridge is level front to back and side to side.

1. If your dual zone bar fridge is not level use the fitted stabilising feet to level.
2. To level unscrew the low corner stabilising bolt out until dual zone bar fridge is level.
3. Once level lock the stabilising foot by screwing the locking nut up to the underside of the dual zone bar fridge body.

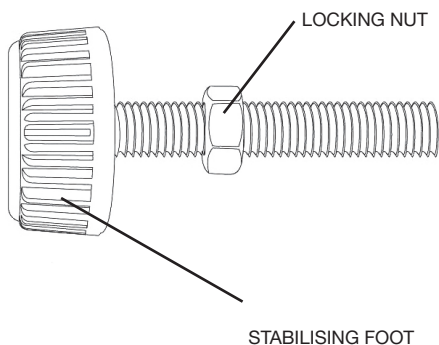

USING STABILISING FEET WITH:

Platinum II BBQ Series Marble Top

(top sold separately)

1. Place Platinum Marble Top onto dual zone bar fridge as per top instructions.
2. If the overall combined unit is too low unscrew each of the 4 stabilising feet so that the combined unit is the same height as the BBQ and modules.
3. Check combined unit is level.
4. If your dual zone bar fridge is not level, use the fitted stabilising feet to level.
5. To level unscrew the low corner stabilising feet out until dual zone bar fridge is level.
6. Once level lock the stabilising feet by screwing the locking nut up to the underside of the dual zone bar fridge body.

MAINTENANCE

- The dual zone bar fridge should be cleaned and maintained regularly with a soft clean cloth.
- When performing maintenance, make absolutely sure that the power plug is first disconnected from the power outlet.
- Wipe the inner and outer surface of the dual zone bar fridge and its accessories with soft clean wet cloth. If they are too dirty, scrub them with neutral detergent, and then clean them with water and dry them with a clean cloth.
- Never use hot water, petrol, alcohol, kerosene, abrasive powder, alkaline detergent, acid, oven cleaners, etc. These could damage the lacquer finish and plastics.
- If the plastic parts in dual zone bar fridge become contaminated by oil (animal or vegetable), they could become brittle and possibly cracked.

TROUBLE SHOOTING

1. If the dual zone bar fridge does not work:

Check if there is a power failure.

Check if the power plug is plugged into the power outlet.

Check that the R.C.D. has not been tripped.

If ambient temperature is above 40°C the Thermal Safety Cut may have operated. Check if unit has restarted once ambient temperature is below 25°C.

2. If the dual zone bar fridge is cooling excessively:

The temperature control dial may be set too high. If you place drinks containing a lot of water directly under the cool air outlets they may freeze. This does not indicate a malfunction.

3. If the dual zone bar fridge is not cooling sufficiently:

The drinks may be packed too tightly together which will block the flow of cool air. You may have put something hot or a lot of drinks into the dual zone bar fridge. The door may not have closed properly. There may be insufficient clearance between the dual zone bar fridge and the other surfaces, both sides, back and above. The temperature control dial may not be set low enough.

4. If condensation forms on the outside of the dual zone bar fridge:

Small amount of condensation may form on the outside when the humidity is high. It does not indicate a malfunction. Wipe dry with a cloth.

5. If you hear a sound like water flowing:

A sound like water flowing is the refrigerant flowing. It does not indicate a malfunction.

6. If the cabinets side and front panel heats up:

The front and side panel of the cabinet will heat up when the door is opened and closed frequently, when starting the unit and when the unit operates in summer with high ambient outside temperature. Do not touch the front or side panel, it is a result of heat from inside the cabinet. It does not indicate a malfunction.



CAUTION

- Never lick icy drinks when they first come out of the dual zone bar fridge. This can freeze burn your lips and mouth.
- If the supply cord is damaged, it must be replaced by professional electrician. The cord must be replaced with a cord of the same specification.
- Before you throw away your old dual zone bar fridge, take off the door, leave the shelves in place, so that children may not easily climb inside.
- Never allow children to operate, play with or crawl inside the appliance.
- This dual zone bar fridge is not designed for perishable foods. It is a drinks dual zone bar fridge.

TECHNICAL SPECIFICATIONS

Specifications are subject to change without prior notice.

If the technical specifications are different from the plate on the back of the dual zone bar fridge, please refer to the plate.

Model	GMF200
Doors	2
Capacity	200L
Rated Voltage	220 ~ 240V AC
Rated Frequency	50Hz
Rated Current	1.35A
Rated Input Power at 240V AC	230W
Energy Consumption	2.23 kW-h/24h
Light	3W + 3W
Lamp Type (x2)	T5
Noise Level (db@3m)	52 db
Refrigerant	R134a
Refrigerant Charge Volume	100gm
Foam Blowing Agent Insulation	Cyclopentane
Nett Weight	52.5kg

GASMATE DUAL ZONE BAR FRIDGE PRODUCT RANGE - WARRANTY STATEMENT

SITRO GROUP AUSTRALIA (S.G.A.) WARRANTS THE PURCHASER OF THIS PRODUCT AGAINST DEFECTS IN WORKMANSHIP AND MATERIALS FOR THE FOLLOWING PERIODS FROM THE DATE OF PURCHASE:

For domestic use, this table applies: -

Dual Zone Bar Fridge Body Stainless Steel	1 Year (surface rust excluded)
Dual Zone Bar Fridge Body Powder Coated	1 Year (surface rust excluded)
Compressor	1 Year
All Other Items	1 Year

For commercial use : - 3 Months

This warranty is not transferable to a subsequent purchaser if the product is sold by the original purchaser during the warranty period.

If a warranty fault appears within the warranty period, S.G.A. reserves the right to replace or repair the product.

In the event that S.G.A. chooses to replace the product, this original warranty will expire at the original date.

If the product includes various accessories or components, only the defective accessory or component will be replaced or repaired.

S.G.A. reserves the right to replace defective parts of the product with parts and components of similar quality, grade and composition where an identical part or component is not available.

Products presented for repair may be replaced by refurbished products of the same type rather than being repaired. Refurbished parts may be used to repair the products.

To make a warranty claim, first contact S.G.A.'s Customer Service Line on the contact number below.

The purchase receipt for this product is to be retained and must be presented if making claim under the terms of this S.G.A. warranty.

Warranty repairs are free of charge, provided the product is delivered to our Service Department at 33-35 Lionel Road,

Mt Waverley, Victoria, 3149 or to one of our Authorised Service Agents.

If a warranty fault is found the freight cost will be credited to the owner. If no fault is found the product will be returned and any costs associated with the service will be charged to the owner.

Products sent freight forward will not be accepted. In most cases the defective accessory or component only will need to be returned. The product or part of the product being returned must be adequately protected in a box.

S.G.A. will not be responsible for any in-transit loss or damage.

This warranty does not apply to any defect, deterioration, loss, injury or damage occasioned by or as a result of misuse or abuse, negligent handling or storage, normal wear and tear or if the product has not been installed and used in accordance with S.G.A.'s instructions, recommendations and specifications or if the product has been subjected to abnormal conditions. The warranty does not apply to blockages caused by insects or living organisms.

The warranty is void if there is evidence of the product being tampered with by unauthorised persons.

The warranty does not extend to installation or disconnection costs.

Our goods come with guarantees that cannot be excluded under the Australian Consumer Law. You are entitled to a replacement or refund for a major failure and for compensation for any other reasonably foreseeable loss or damage. You are also entitled to have the goods repaired or replaced if the goods fail to be of acceptable quality and the failure does not amount to a major failure. The benefits of this warranty are in addition to any rights and remedies imposed by Australian State and Federal legislation that cannot be excluded.

Electric Products Approved For Outdoor Use Only

For warranty claims, service, spare parts or products information in Australia, please call SITRO GROUP AUSTRALIA Pty Ltd on the Customer Service Line 1300 174 876

Register your Warranty online at

www.gasmate.com.au

A receipt or proof of purchase is required and must be kept for your records.

Note: If you do not have internet access call our customer service team on 1300 174 876



CONTACT DETAILS

Sitro Group Australia Pty Ltd
33-35 Lionel Road, Mt. Waverley
Victoria 3149, Australia.
Tel (+613) 9543 9533
Fax (+613) 9543 9839
sales@sitro.com.au

For any queries or assistance call



Customer Service
(Australia Only)

1300 174 876

Hours of operation:
Monday to Friday 8.30am - 5.30pm EST

Do not return to place of purchase.
Keep your purchase receipt, this will be required to
make any claims under the 12 month warranty.

Gasmate[®]